

# Panasonic®

Sirius Satellite Radio



## CR-SRF100 CR-SRT100 Operating Instructions



CR-SRF100 (SHOWN)

# Sirius Satellite Radio Automatic Level Control (ALC)

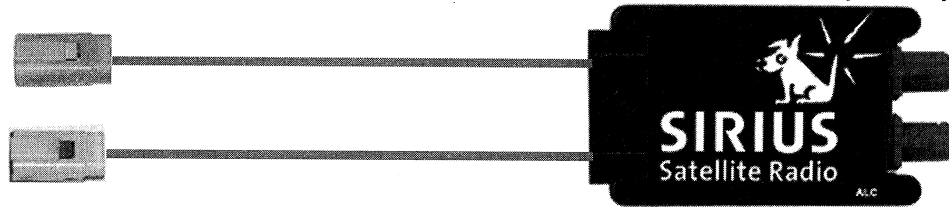

Fig. 1

## IMPORTANT NOTE:

ALC Module (Fig.1) **MUST BE** used in line between Sirius Satellite Receiver and antenna. **DO NOT** attempt to connect antenna directly to receiver. Please see diagram below (Fig. 2).

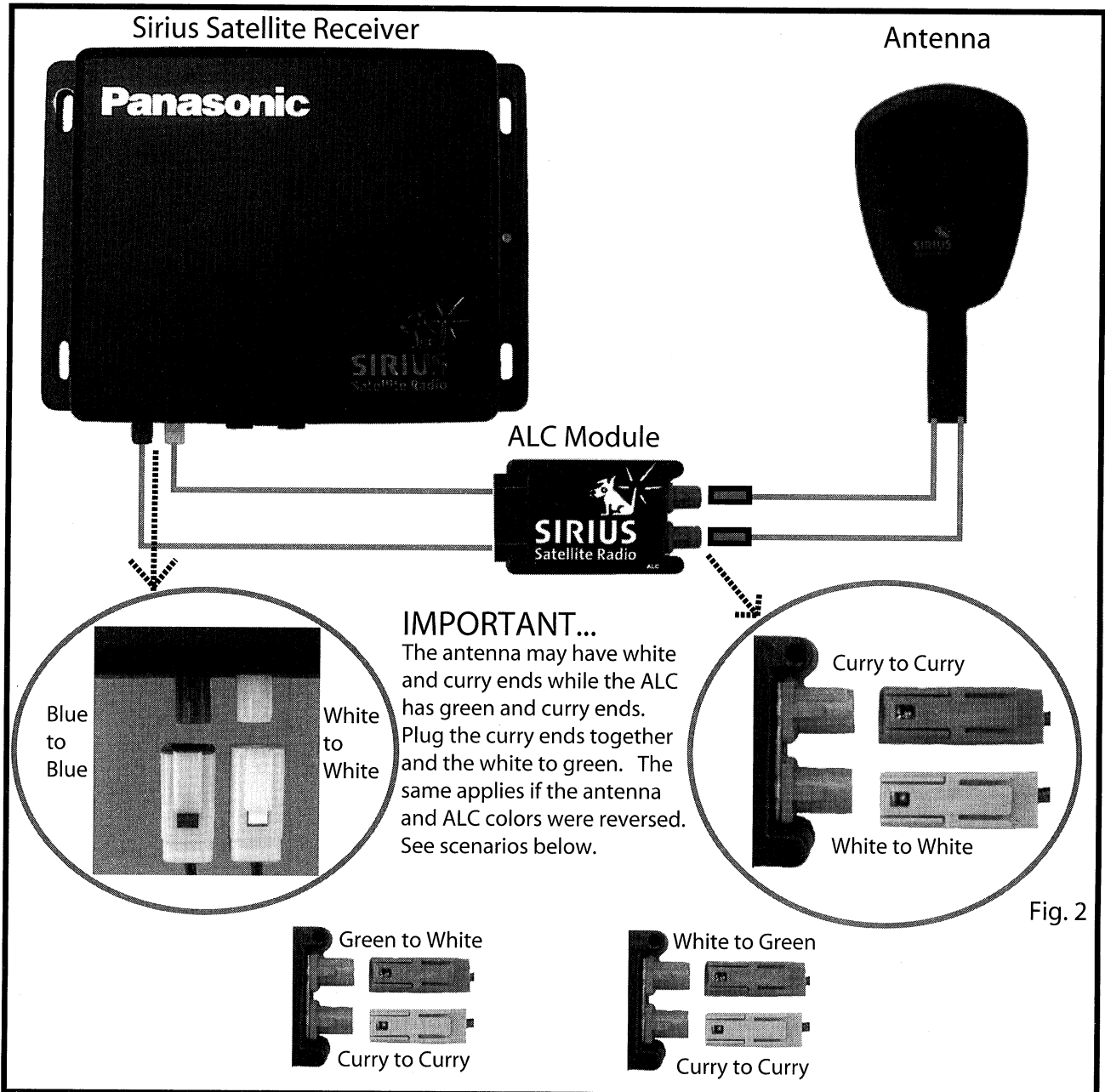

Fig. 2

---

The contents of this manual are subject to change without notice and do not constitute a commitment on the part of Matsushita Communication Industrial Corporation of USA (MCUSA). Every effort has been made to ensure the accuracy of this document. However, due to ongoing product improvements and revisions, MCUSA cannot guarantee the accuracy of printed material after the date of publication, nor can it accept responsibility for errors or omissions. MCUSA will update and revise this document as necessary.

The software and hardware described in this document may be used or copied only in accordance with the terms of the license pertaining to said software or hardware.

Copyright © 2002 by Matsushita Communication Industrial Corporation of USA (MCUSA). All rights reserved.

# Table of Contents

---

1. ACRONYMS & ABBREVIATIONS	4
2. BASIC FEATURES	4
3. WHAT IS SIRIUS SATELLITE RADIO (SSR) (SUMMARY DESCRIPTION)	5
4. PRECAUTIONS	7
5. GETTING INITIAL SUBSCRIPTION FOR CHANNELS FROM SIRIUS	8
6. SETUP MODE	9
6.1. Enter & Exit Setup Mode	10
6.2. Select a Setup Item	11
6.3. View the Sirius ID	12
6.4. Change the Display Brightness	13
6.5. Setup FM Modulator Frequency	14
7. BASIC OPERATION	17
7.1. General Descriptions	17
7.1.1. CDU Controls	19
7.1.2. CDU Communication to the Operator	19
7.2. Start-Up/Shut-Down Modes	20
7.2.1. Start-Up (Turn On)	20
7.2.2. Shut-Down (Turn Off)	22
7.3. Standard Operations & Screen Display Format	23
7.4. Category Mode	29
7.5. Channel Mode	31
7.6. Preset Mode	32
8. SYSTEM COMPONENTS & SPECIFICATIONS	34
8.1. SSR Receiver ... (CR-ZX0161Z)	35
8.2. Control Display Unit (CDU) ... (CY-CX0160Z)	36
8.3. FM Modulator ... (CY-ZX0160Z)	37
8.4. Receiver Wiring Harness ... (M2C457018)	38
8.5. Receiver Wiring Harness ... (M2C457019)	39
9. DIAGRAMS & INSTALLATION	40
9.1. General System Diagrams	40
9.2. General Connection Diagram	42
9.3. Installation	44
10. MAINTENANCE & TROUBLESHOOTING	47
Notes	50

# WELCOME

---

Panasonic welcomes you to their constantly growing family of electronic products owners. We endeavor to give you the advantages of products with precise electronic and mechanical engineering, manufactured with carefully selected components, and assembled by people who are proud of the reputation their work has built for our company. We know this product will bring you many hours of enjoyment, and after you discover the quality, value and reliability we have built into it, you too will be proud to be a member of our family.

## 1. Acronyms & Abbreviations

---

- CDU: Control Display Unit
- SEL: The "SELECT" button/knob.
- PDT: Program Descriptive Text
- SSR: Sirius Satellite Radio
- SDARS: Satellite Digital Audio Receiver System

## 2. Basic Features

---

The SSR system allows you to receive up to 100 channels of programming with coast-to-coast reception and quality sound. Some of the main features are listed below:

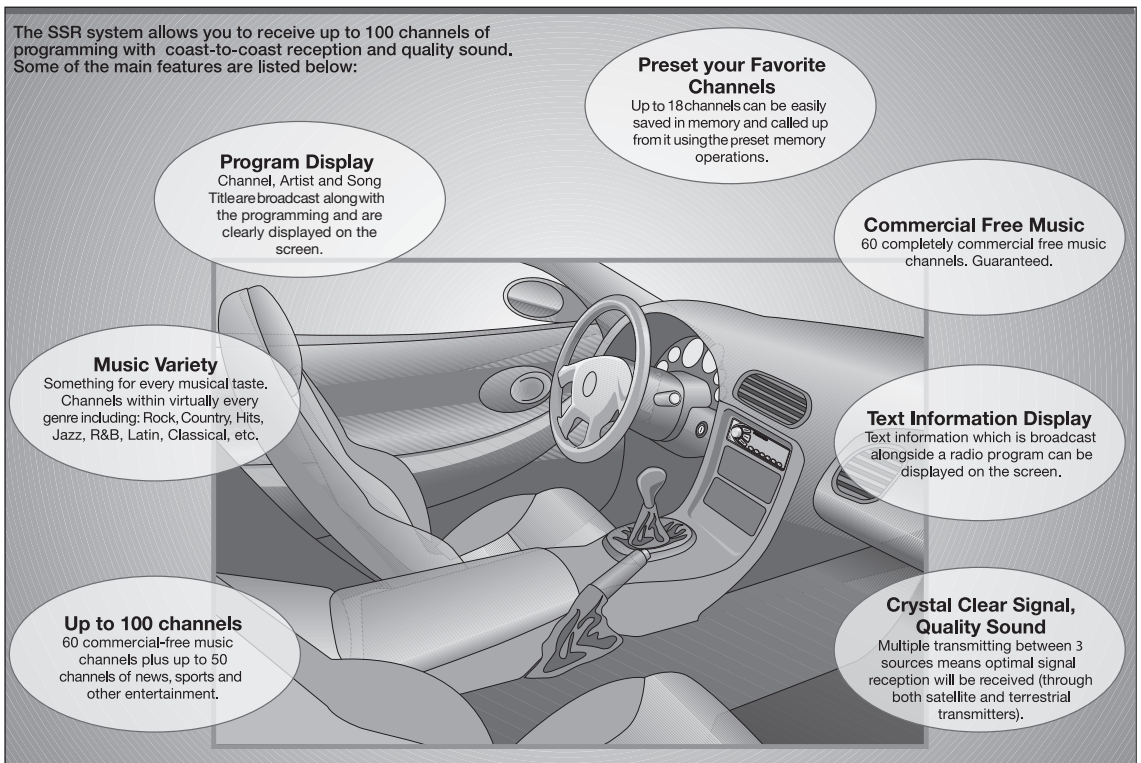

---

# Summary Description

## The Service

100 channels of music, news, sport, and other entertainment. 60 channels of 100% commercial-free music. All broadcast directly to your vehicle, anywhere in the continental United States.

## The Programming

There are no painfully repetitive play lists. Music is hosted live by Master Music Programmers and on-air personalities who are true experts in their fields. When they do speak, it's to give you some information regarding the music being played.

## Channel to Category Organization

Channel and Category organization can be illustrated as:

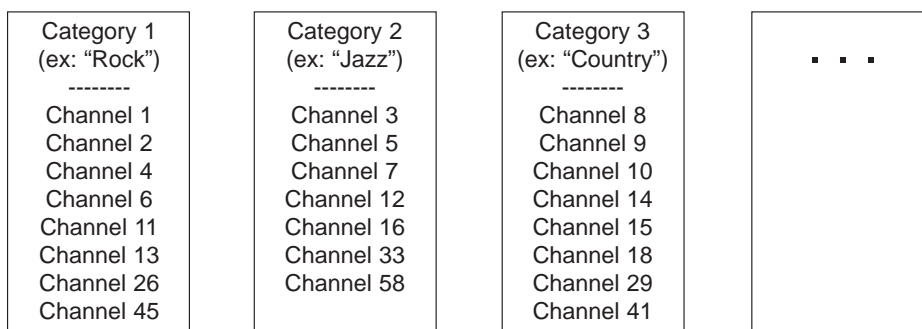

## Displayable Information

The different types of displayable information are:

- Category: Name of category.
- Channel: Name of channel and channel number.
- Program / Song: Program Descriptive Text (PDT) data ... such as:
  - Current Artist Name
  - Current Album Name
  - Current Song Title
  - Record label for current song
  - "other current information"

## Primary Components

There are 5 basic components to the SSR system:

1. SSR Receiver
2. Antenna (Sold Separately)
3. Controller / Display Unit (Included in CR-SRF100)
4. FM Modulator (Included in CR-SRF100)
5. Receiver Wiring Harness

---

## The Technology

The Sirius Satellite Radio service begins at the national broadcast studios in New York City, where the programs are created. They are then beamed to the three orbiting satellites and ground repeaters, which then send them to the receiver in your vehicle. This signal is maximized by placing the satellites in orbits directly above the United States rather than geostationary orbits over the equator. The result is the most optimal signal strength.

This system is broadcast in the S-Band and has a frequency range of 2319.75MHz to 2332.75MHz.

## A Note About Reception

Satellite signals may be completely blocked by buildings, overpasses, or other structures and they operate best with a “clear line of sight.” For this reason, terrestrial repeaters are placed in dense urban areas to supplement the satellite coverage area.

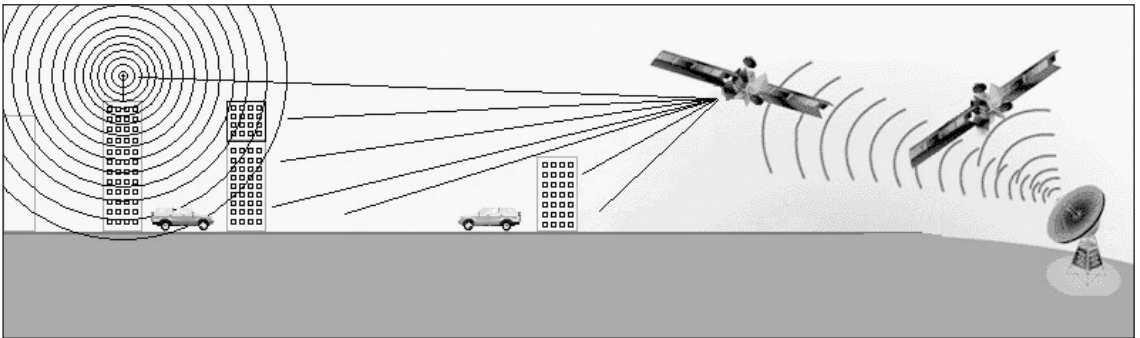

In the illustration above (not drawn to scale), the satellite signal is prevented from directly reaching either vehicle. However, the vehicle on the left is within range of a terrestrial repeater and therefore can receive broadcast until it emerges from the “electronic shadow” of the building.

Not: the Sirius broadcast satellites orbit almost directly overhead so their “shadow” is very small. However, the satellite’s precise location in the sky changes hour by hour and the corresponding “shadow” will change as well.

Momentary interruption of the satellite signal is protected by a four-second audio memory in the receiver. Therefore, if the signal blockage exists for less than four seconds, there will be no interruption of the audio.

The combination of overhead placement, terrestrial repeaters, and the four-second audio memory should provide coast-to coast coverage with few interruptions.

# 4. Precautions

---

## CAUTIONS

- This product is designed to operate off a 12 volt, negative ground battery system.
- To prevent damage to the unit, be sure to follow the connection diagram in section 9.2.
- Do not insert the power connector into the unit until the wiring is completed.
- Be sure to insulate any exposed wires from a possible short-circuit to the car chassis.  
Bundle all cables and keep cable terminals free from touching any metal parts.
- Noted that if your car has a driving computer or navigation computer, disconnecting the battery cables may cause the contents of memory for these computer to be lost.

## MAINTENANCE

Your product is designed and manufactured to ensure the minimum of maintenance. Use a soft cloth for routine exterior cleaning. Never use benzine or other solvents.

## WHEN SOMETHING DOESN'T WORK

Check the Maintenance and Troubleshooting on pages 47 through 50 for possible causes and the problem you might be experiencing. Some simple checks or minor adjustment may eliminate the problem.

## FOR PRODUCT SERVICING

If you experience any operational difficulties, or require a repair, please refer to the original installer or your supplying dealer for assistance. Otherwise, call Panasonic Customer Service 1-800-211-PANA (7262) for assistance.

## REPLACING THE FUSE

Use fuses of the same specified rating 3A for yellow wire and 0.5A for red wire. Using different substitutes or fuses with higher ratings, or connecting the unit directly without a fuse, could cause fire or damage to the receiver system. If the replacement fuse fails, contact the Panasonic Customer Service 1-800-211-PANA for assistance

## CAR WASHING

To avoid electrical shorts which may cause fire, or other damage, do not expose this product to water or excessive moisture.

## PRODUCT & SIRIUS SERIAL ID NUMBERS

It is especially important to retain the unit's product serial number and the electronic Sirius Identification Number for service activation and potential future service changes.



# 5. Getting Initial Subscription

## For Channels From Sirius

If your system has been powered up and a subscription for satellite services has already been done, then SKIP this section...you are ready to finish setting up the system or operate it.

Only continue with this section after the system is installed in the vehicle and the battery is connected.

There are 3 basic steps:

1. Turn the power on by pressing the [SEL] knob/button.

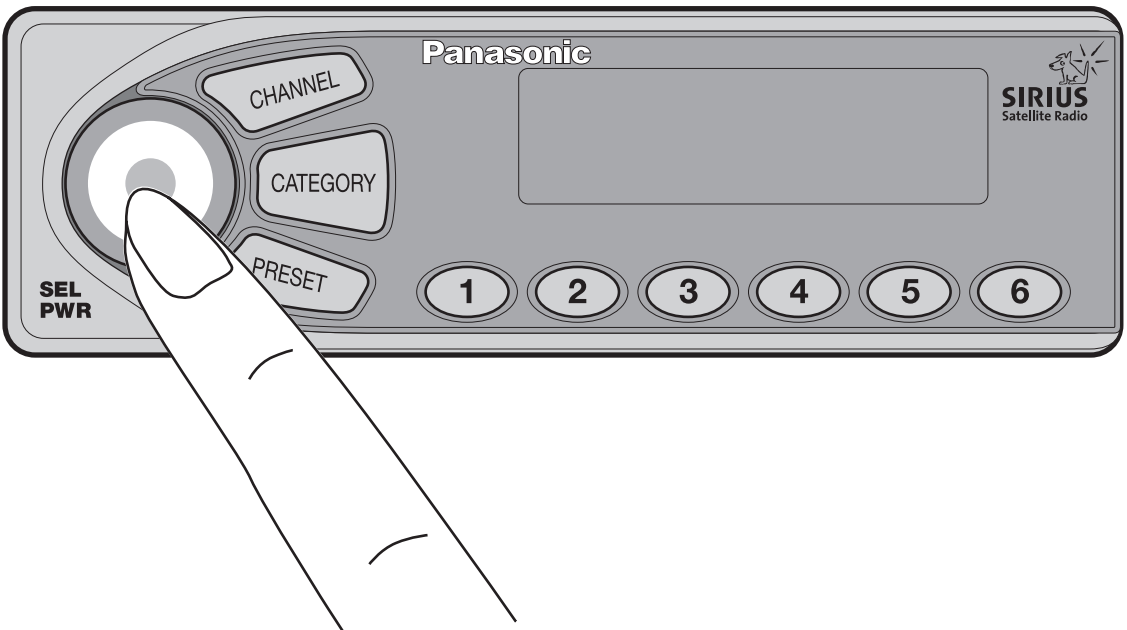

(the unit's Sirius ID number should be displayed)  
(if the ID number is not displayed, skip this section ... already subscribed!)

Note: If this is the first time the radio has been powered on, please leave the unit powered up for approximately 5 minutes without operating the controls. There is transmission-specific information which must be loaded into the receiver from the satellite signal.

2. Record the receiver's product serial number (printed on a label on the receiver) and Sirius ID number from the display. (See section 6.1 for information on displaying the Sirius ID.)



---

You are now ready to activate your service. You have one of two options:

1) Visit the website at: <http://www.siriusradio.com>

Click on the “JOIN” section and follow some simple directions.

2) Call toll-free 1-888-539-SIRIUS (7474) and one of the customer care representatives will take the necessary pieces of information and walk you through the activation process.

Please have the following ready when attempting to activate your service:

- Sirius ID number
- Valid credit card information (number & expiration).

Note: After your unit is activated, you may need to rotate the SEL knob to begin playing audio.

## 6. Setup Mode

---

Setup mode is used to set the various radio system parameters and display information. It is not expected to be used often; therefore a dedicated setup mode button does not exist.

### LIST OF SETUP OPERATIONS IDENTIFIED

The following operations are available to the user:

1. Entering & Exiting Setup Mode
2. Selecting a Setup Item
3. View the Electronic Sirius ID
4. Change the display brightness
5. Setup the FM modulator frequency

# 6.1. Enter & Exit Setup Mode

## ENTERING SETUP MODE

A user enters setup mode by pressing the [1] and [6] buttons simultaneously. The system then displays the setup mode screen, with viewing the Sirius ID as the first setup item choice.

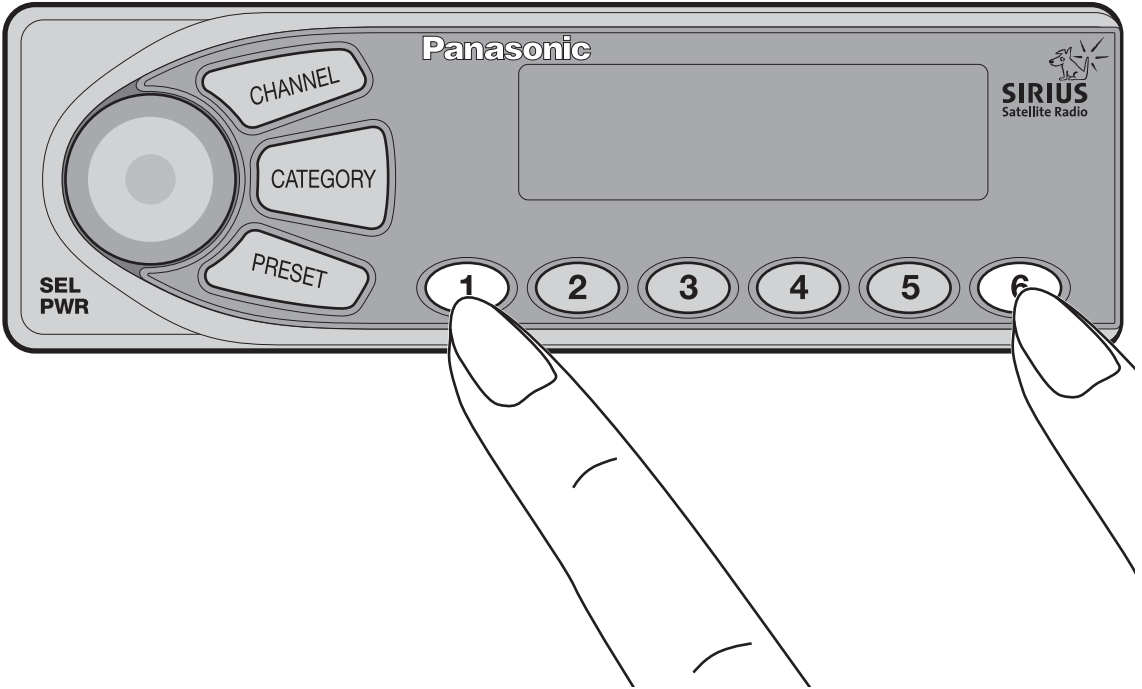

## EXITING FROM SETUP MODE

You may exit setup mode by entering a different mode (press and release [CHANNEL] or [CATEGORY] or [PRESET] buttons).

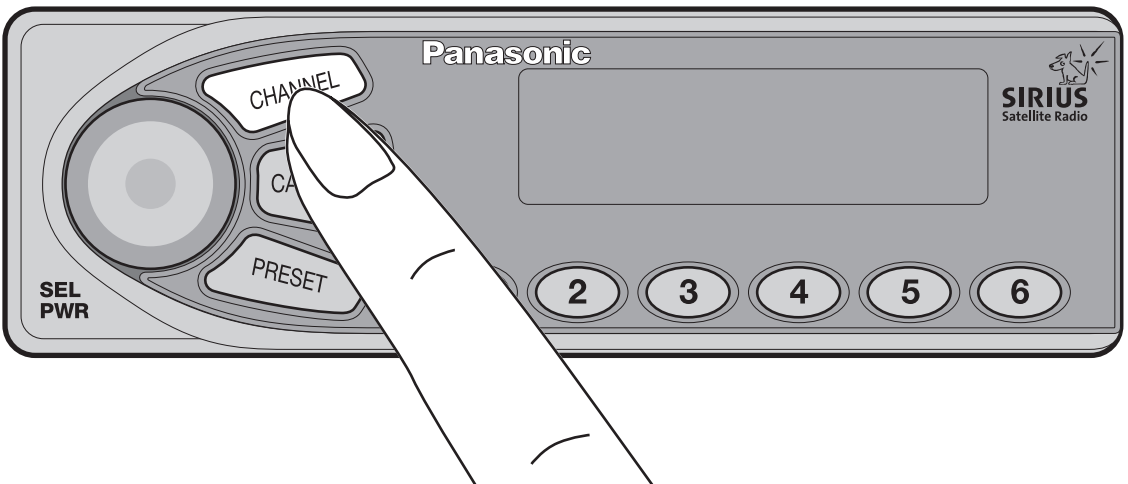

## 6.2. Select a Setup Item

---

When in setup mode, the [SEL] knob is used to navigate to the different setup screens. Pressing and releasing the [SEL] knob will move to the next setup item.

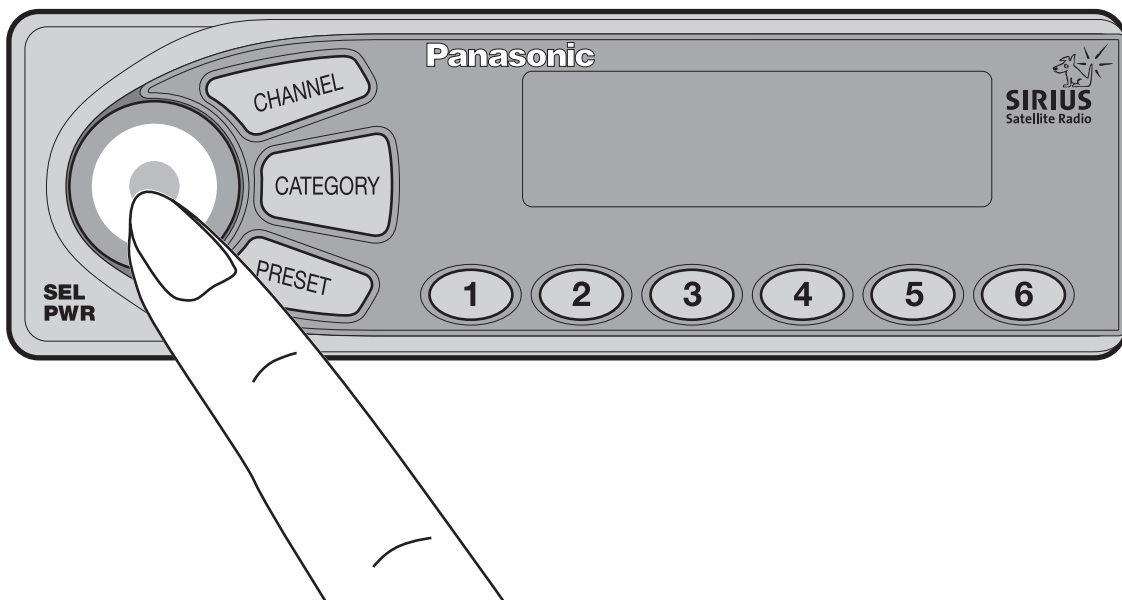

Where appropriate, rotating the [SEL] knob will move to the next selection within the current setup item.

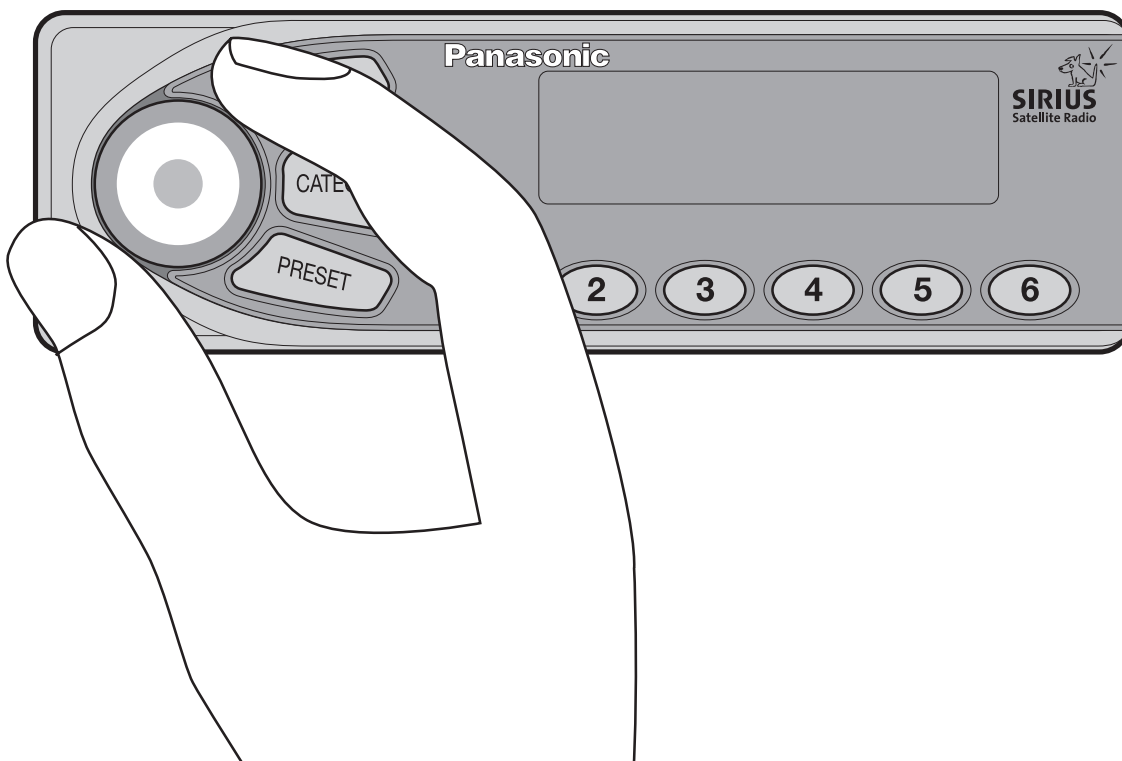

## 6.3. View the Sirius ID

---

The Sirius ID Number is displayed on the CDU when setup mode is entered [SECTION 6.1]. Pressing the [SEL] button moves to the next setup item. Rotating the [SEL] button has no effect.

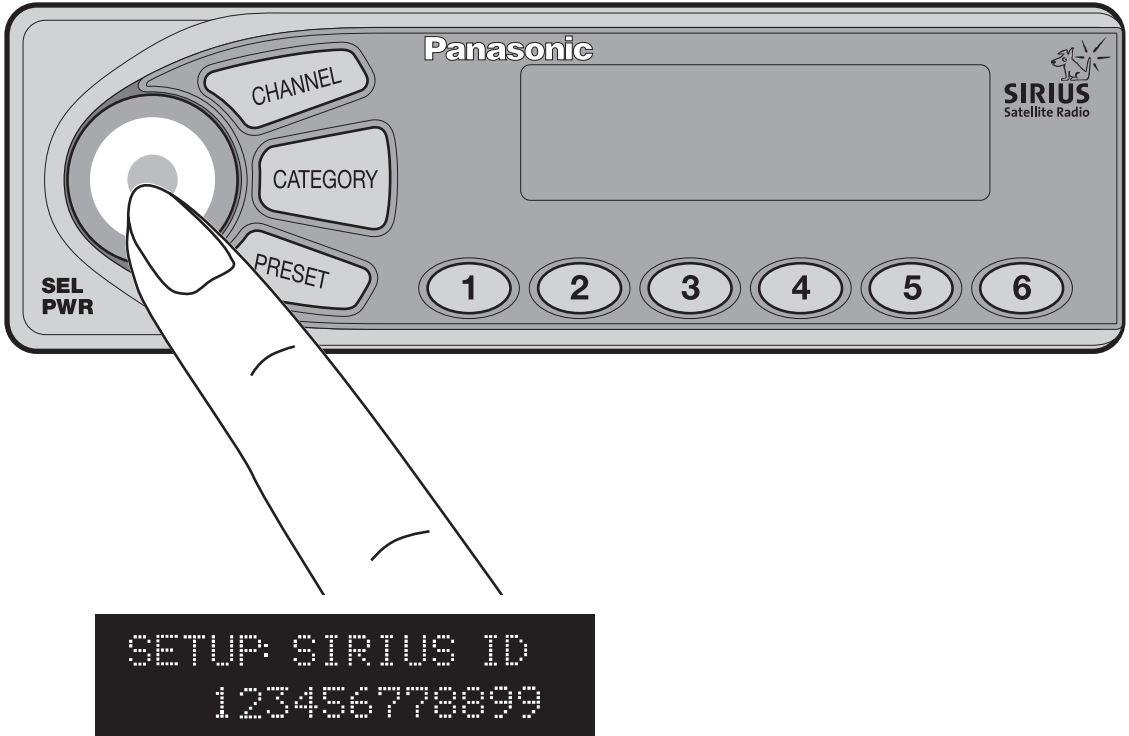

# 6.4. Change the Display Brightness

## ENTER SETUP MODE [SECTION 6.1]

When the Adjust Brightness setup option is selected by pressing the [SEL] button, the brightness of the character display is changed. You may select between 4 brightness levels (25% [dimmest], 50%, 75%, 100% [brightest]) by rotating the [SEL] knob. Pressing the [SEL] button selects the brightness level currently displayed and moves the user to the next setup item.

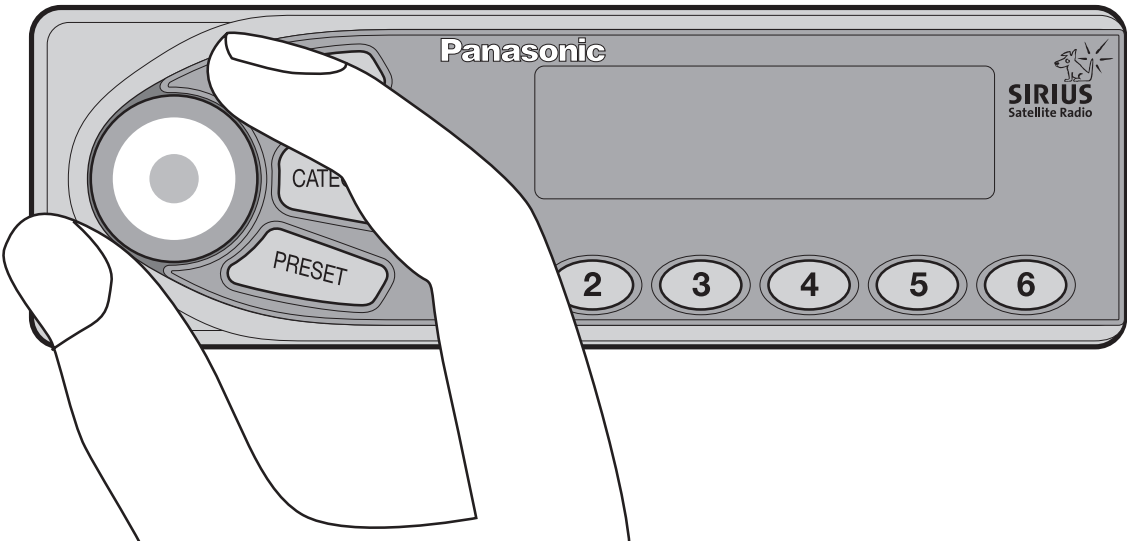
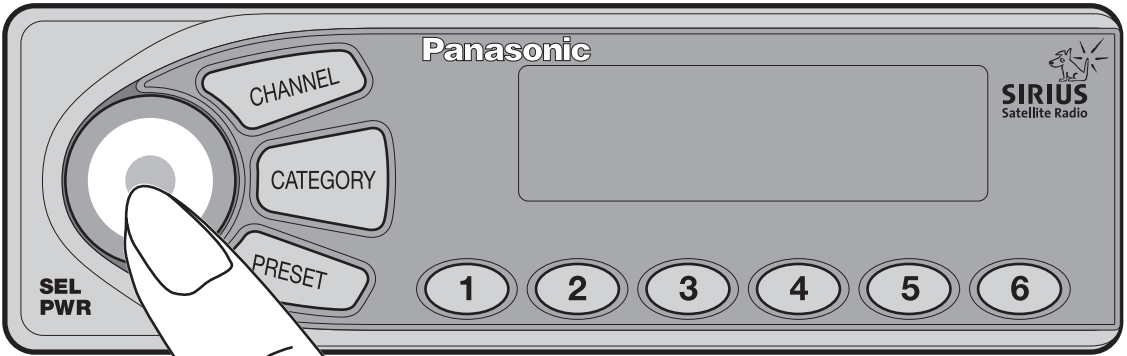

# 6.5. Setup FM Modulator Frequency

Please disregard if an FM modulator is not in your system.

The Sirius receiver has the capability to send audio output to an FM radio by means of a hardware FM modulator. This option is enabled through the setup mode, and the FM frequency is set up as well.

Below is a table of the 11 FM Modulator settings available: the “OFF” state and the 10 frequency settings. The CDU displays the frequency (MHz) or OFF when in this mode.

When the [SEL] knob is rotated, the system increments or decrements the modulator frequency according to the table. It is recommended that an unused frequency currently with no FM broadcast be used for the FM Modulator frequency. Pressing the [SEL] button selects the modulator frequency currently displayed and moves the user to the next setup item.

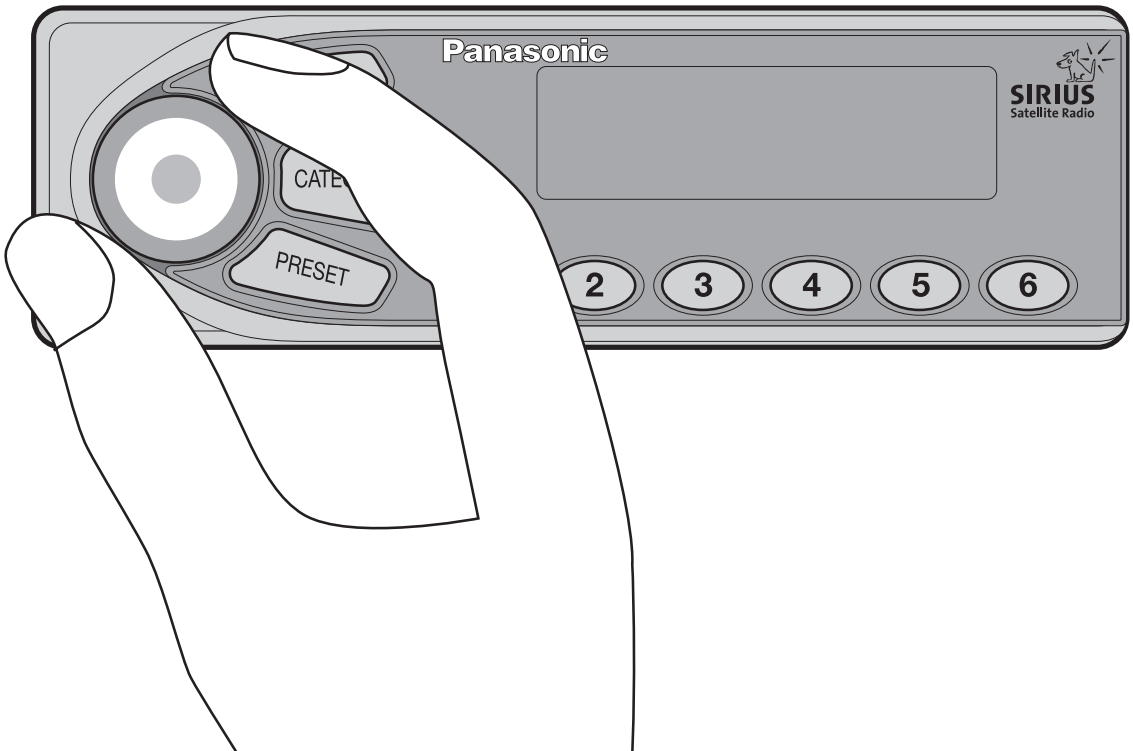

SETUP  
FM CHANNEL 88.7

---

Index	Frequency
0	OFF
1	88.7 MHz
2	88.9 MHz
3	89.1 MHz
4	89.3 MHz
5	89.5 MHz
6	89.7 MHz
7	89.9 MHz
8	90.1 MHz
9	90.3 MHz
10	90.5 MHz

If you try to use the Sirius Satellite Radio system with an FM modulator and you don't have the radio tuned to the correct frequency, you might only hear static. The radio must be on the same FM station as the SSR system is set.

For convenience, we recommend you assign the appropriate FM modulator frequency to one of the preset buttons on your FM radio.



# 7. Basic Operation

---

“Power up” means turning the unit on from a Control Display Unit (CDU) on a system that has

- been properly installed and battery power supplied.
- already engaged a channel subscription from Sirius.

## 7.1. General Descriptions

---

### CATEGORY

A category is a group of channels having a similar theme or “genre” (for example “ROCK” or “JAZZ”). There are “at least” 12 categories ... each having a maximum of 24 channels.

### CHANNEL

A channel can be thought of as a single radio station. You can receive up to 100 channels on your receiver. The channel NUMBERS assigned to channels can be over 100. Some channel numbers might not be available for one reason or another. A channel NAME that gets displayed might be something like: “THE VAULT” or “CLASSIC COUNTRY”.

Sirius assigns channels to categories. Channel numbers may change in the future but the receiver will keep up with these changes. You might want to periodically re-check the presets. Also, a single channel may be in multiple categories.

### PROGRAM DESCRIPTIVE TEXT

Program Descriptive Text (PDT) data is song (or program) specific textual information that is transmitted to the receiver and displayed on the CDU. An example of some PDT data for a song might be:

- |                |                        |
|----------------|------------------------|
| • Artist Name  | “The Police”           |
| • Song Title   | “Roxanne”              |
| • Album Name   | “Every Breath You Take |
| • Record label | “A & M Records”        |

Generally, most stations will at least contain the artist name and song title information. Additional information such as album and record label may also be provided.



---

## PRESET

A preset is a channel number stored in memory that is easily called back by pressing a button. The CDU can store up to 18 preset channels for quick retrieval. There are 6 buttons to store/recall preset channels (numbered 1 ÷ 6). To afford 18 preset channel numbers, the CDU uses 3 groups of 6 presets. To access a particular preset, you only have to select the group of preset values you want and then press the particular preset button.

The preset memory (18 channels) is saved even if the battery power is lost.

## OPERATING MODES

You are always in one of the 4 particular operating modes (SETUP, CHANNEL, CATEGORY, PRESET). The only way to exit one mode is to press the appropriate button(s) to enter a different mode. For example:

- Press and release the [CATEGORY] button: Enters category mode.
- Press and release the [CHANNEL] button: Enters channel mode.
- Press and release the [PRESET] button: Enters preset mode.
- Simultaneously pressing the preset buttons [1] & [6]: Enters setup mode.

# 7.1.1. CDU Controls

- Select knob/push button
- “Channel” Mode button
- “Category” Mode button
- “Preset” Mode button
- Preset buttons (“1”, “2”, “3”, “4”, “5”, “6”)

Select Knob & Power On/Off

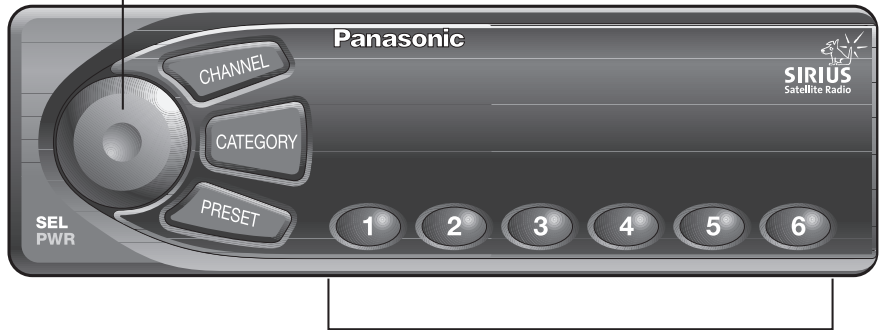

Preset Buttons

# 7.1.2. CDU Communication to the Operator

- Display
- Indicators

Category Indicator

Channel indicator

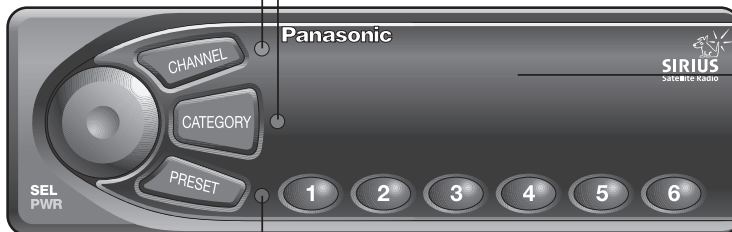

2 Line x 16 Character Display

Preset Indicator

## 7.2. Start-Up/Shut-Down Modes

---

In this section, “On” refers to a condition where the CDU is displaying information and the radio is playing audio. “Off” refers to the condition when the CDU is powered down and there is no satellite receiver audio.

The receiver remains powered as long as there is battery power. Power is supplied to the CDU by pressing the [SEL] button.

### 7.2.1. Start-Up (Turn On)

---

If the SSR system was “On” when the vehicle was last powered off, then it will automatically turn on when the vehicle is started the next time. Otherwise, press and release the [SEL] button to turn the SSR system on. When the SSR system turns on, the following sequence of events will occur:

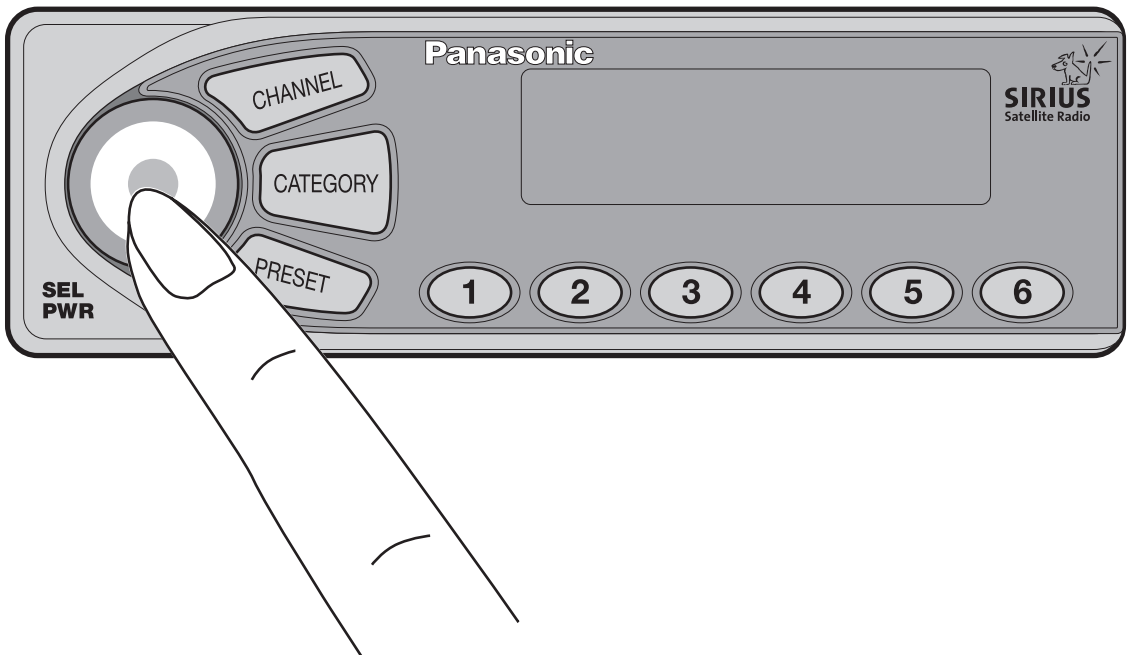

- 
1. "SIRIUS SATELLITE RADIO" will scroll across the display, twice.



2. If there is no antenna detected, "ANTENNA ERROR" will show on the second line of the display:



3. If the antenna is good, but no signal is found, "ACQUIRING SIGNAL" will show on the second line of the display:



4. Once satellite signal is present, the CDU will display the current channel number, category, and name depending upon the current system configuration/setup.



NOTE: If your system is using an FM modulator and you were listening to the radio prior to starting the SSR system, you might need to tune your radio to the appropriate FM frequency. The radio must be on the same FM station that the Sirius Satellite Radio system is set for.

(Please see the section on the setup operation to view or change the required FM modulator frequency) [SECTION 6.5].

## 7.2.2. Shut-Down (Turn Off)

---

Press and hold the [SEL] button for greater than two seconds to turn the system off. The receiver mutes the SSR audio, blanks the CDU display and turns off all indicators. If an FM Modulator is connected to the system, it will switch back to the antenna to allow normal AM/FM radio operation .

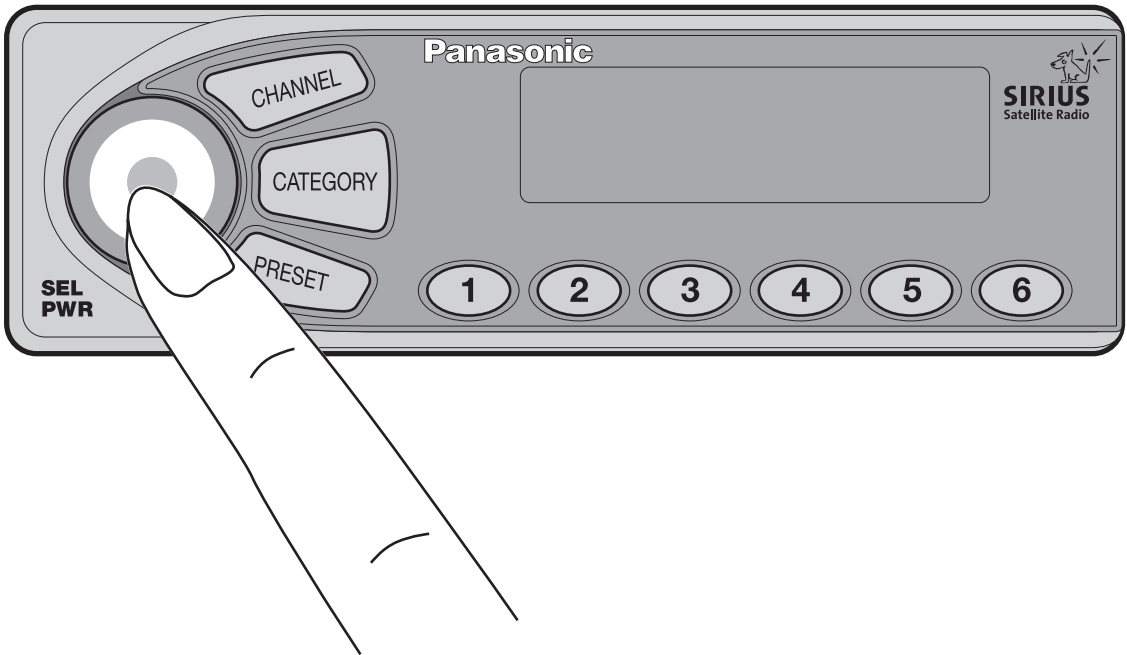

# 7.3. Standard Operations & Screen Display Format

## GENERAL KEYPAD HANDLING CHARACTERISTICS

In general, a function in the CDU is engaged by pressing and releasing the button. If any other button press is detected while the first button is still depressed, the other button(s) function is ignored. The only exception from this is when a function requires simultaneous key presses (e.g., entering SETUP mode). Therefore, in this manual, “press a key” actually means “press and release a key” unless the operation happens after an extended key press (e.g., storing a value in a preset) and then the manual will indicate “press and hold”.

## SCROLLING INFORMATION

When the length of the information to display is greater than the allocated space, the information will scroll across the screen one time and then a shortened version that does not scroll will appear.

## “CHANNEL NAME” SCREEN DISPLAY FORMAT

(this is also called the “DEFAULT” screen display format)

The channel name (default) screen display format is as follows

- 1st line: Channel number & Channel Name
- 2nd line: Category for the current channel being played

## EXAMPLE:

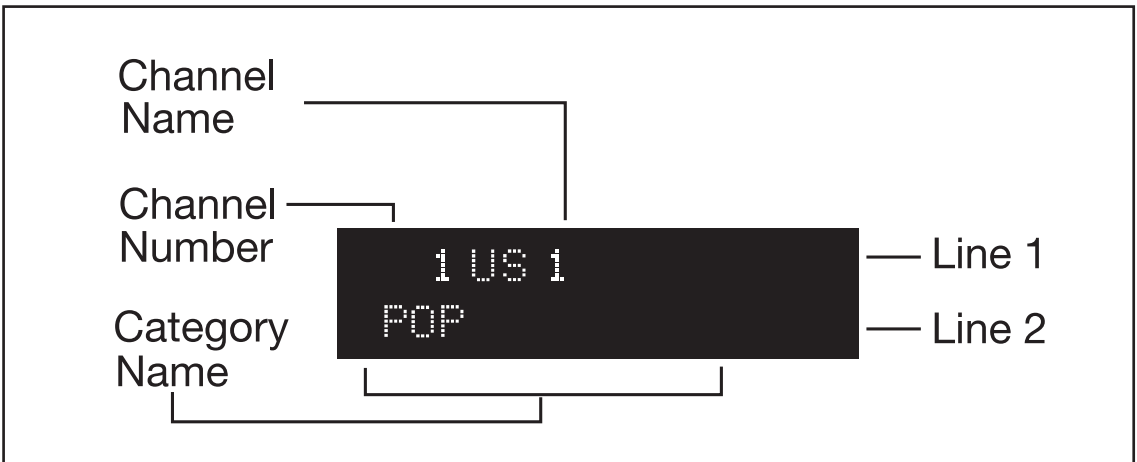

The channel number is displayed in the first four characters of the top line, three digits and a trailing space.

---

The channel name is displayed in the last 12 characters of the top line. If the full channel name is greater than twelve characters in length, then the full channel name is scrolled across the display once, and the eight-character abbreviated version is displayed thereafter.

The category name is displayed on the bottom line. If no category information accompanies this channel, then this area of the display area will be blank.

If you change channels, there can be a slight delay in getting the new information to display. During a channel change, the new channel number is immediately displayed, and the rest of the display is updated when the new information is available.

### **“PDT” SCREEN DISPLAY FORMAT ... CHANGING TEXT INFORMATION BEING DISPLAYED**

Program Descriptive Text (PDT) is available in any of the principle modes of operation (other than SETUP). This information is only displayed on the second line of the display. The first line continues to display the channel number and category name.

The screen display format is as follows

- 1st line: Channel number & Channel Name
- 2nd line: Category name OR PDT information for the specific program

When the operator presses the [SEL] button, the type of information displayed on 2nd line rotates between the channel name and different types of PDT information.

For example, if the

- channel number is: 7
- category name is: “POP”
- channel name is: “I-70”

Then the available PDT data could be:

- Artist Name “The Police”
- Song Title “Roxanne”

The PDT type (“ARTIST” or “TITLE”) is temporarily displayed on the second line immediately before the PDT is displayed.



Then pressing and releasing the [SEL] button will have the following effect:

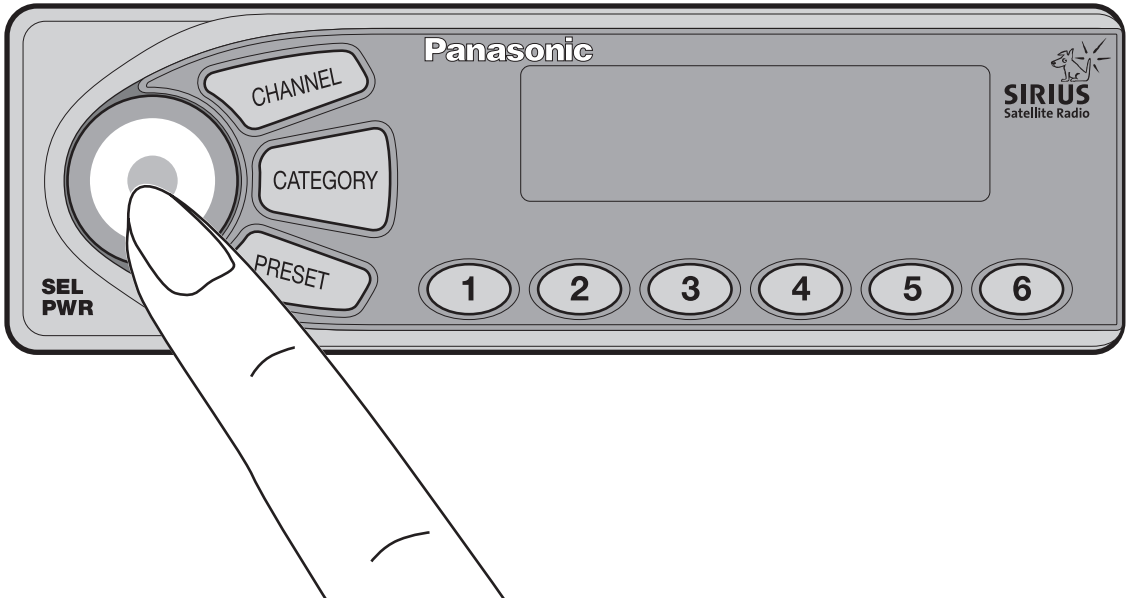

7 I-70  
ARTIST

followed shortly by:

7 I-70  
THE POLICE

And repeated pressing of the [SEL] button will have the following effect:

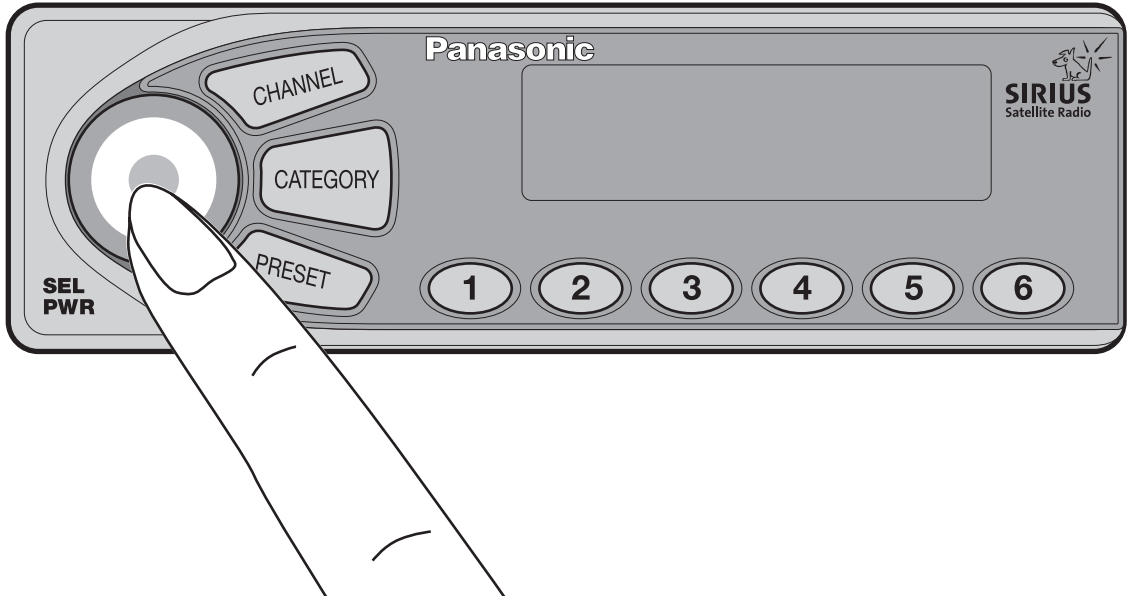

7 I-70  
TITLE

followed shortly by:

7 I-70  
THE POLICE

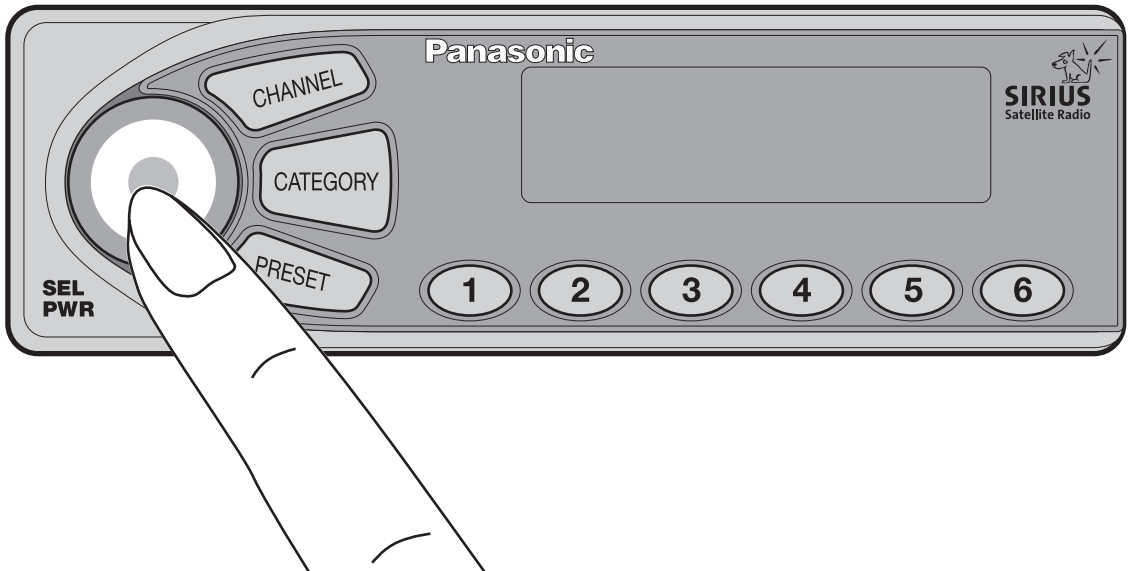

The display reverts to:



If the ARTIST or TITLE information is not available, the words “ARTIST” and “TITLE” are remain in their place. If a PDT field other than ARTIST and TITLE does not contain information the field is skipped and the next field that contains data is displayed.

### DISPLAY WHEN TUNING TO A CHANNEL STORED IN A PRESET

No matter what mode you are in (PRESET, CHANNEL or CATEGORY), if you tune to a channel that is also stored in a preset (rotating the [SEL] knob OR pressing preset buttons [1] – [6]), the system momentarily displays the preset number and group on the lower line of the display before continuing with the pre-selected display format.

If the channel selected is stored in multiple presets:

- If the channel was selected by pressing a preset button [1] – [6] then that preset number & group are momentarily displayed.
- If the channel was selected by any other means (e.g., rotating the [SEL] knob) then the system will momentarily display the first preset number & group that the channel is stored in.

---

### (STORING CHANNELS IN PRESETS

To store a channel in a preset, press and hold the preset button for 2 seconds. The receiver will emit a short beep, indicating the channel is stored at that preset button in the current preset group.

### RECALLING PRESET CHANNELS

If the user presses and releases a preset button [1] – [6] the system will select the channel stored at the preset number for the current preset group.

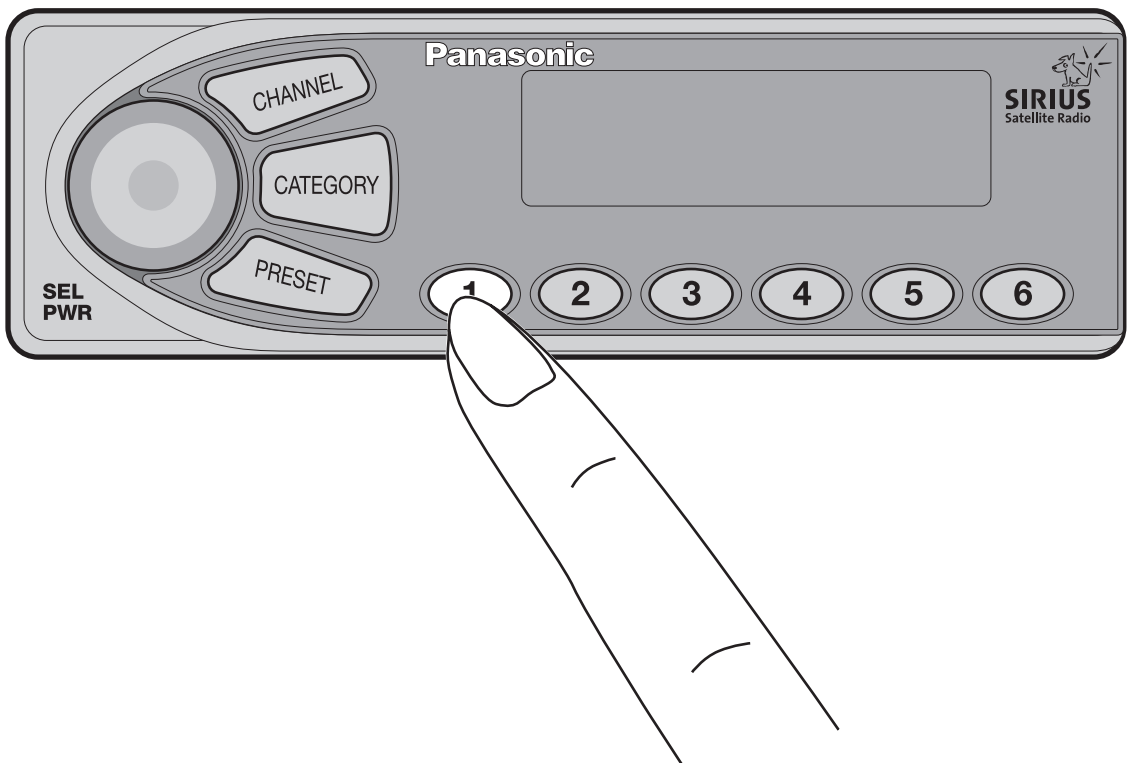

# 7.4. Category Mode

The Sirius satellite system collects category information about each available channel. Any given channel may be associated with zero, one, or more than one category. Therefore a category map is constructed with each category identified with the specific channels associated with it.

This channel and category mapping can be illustrated as:

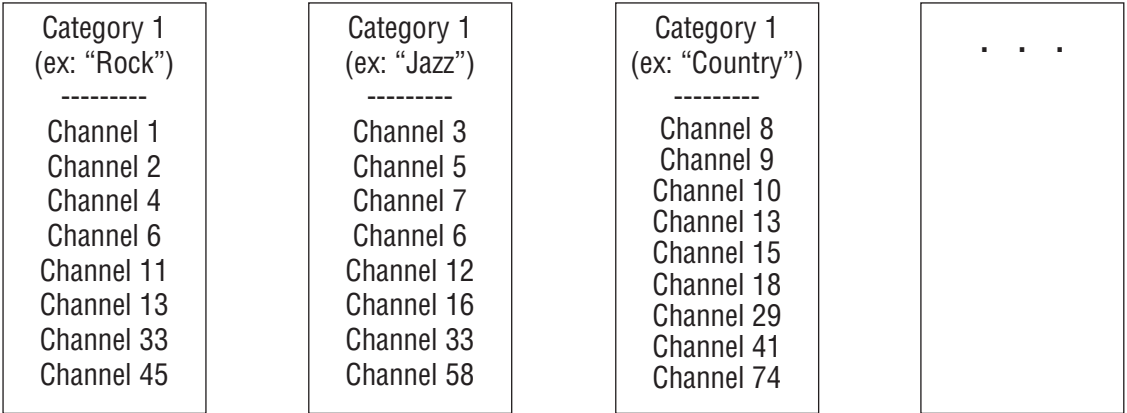

Through the use of preset buttons or by being in channel mode, it is possible to tune to a channel not in the currently selected category.

## ENTERING CATEGORY MODE

You enter category mode by pressing and releasing the [CATEGORY] button. The system indicates entering category mode by illuminating the category mode indicator located next to the category button.

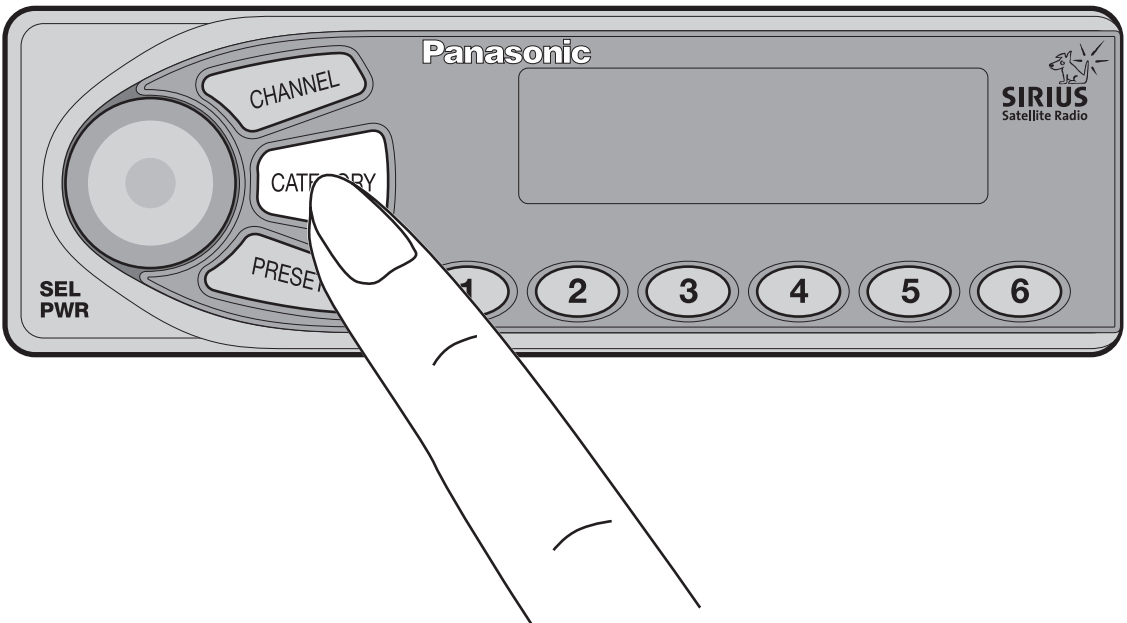

## EXITING FROM CATEGORY MODE

You exit category mode by entering a different mode. There are several ways to do this ...

- press the [CHANNEL] button to enter CHANNEL mode.
- press the [PRESET] button to enter PRESET mode.
- enter SETUP mode.

The system indicates exiting category mode by turning off the category mode indicator located next to the category button.

## SELECTING A CATEGORY

You select a category by pressing the [CATEGORY] button until the desired category is displayed. If the category mode screen is not currently being displayed, the first press of the [CATEGORY] button results in the current category being displayed. Further presses of the [CATEGORY] button selects the next category.

The category mode screen will be displayed for a fixed time after the last button press of [CATEGORY]. After that, the system returns to the standard display format ... leaving the last category selected as the current category.



The channel is not changed when pressing the [CATEGORY] button. The channel changes once you rotate the [SEL] knob/button (which changes the channel). At this time, if the category display screen is being displayed, the CDU immediately returns to the previous display format.

## CHANNEL SELECTION WITHIN CATEGORY MODE

As the [SEL] knob is rotated, the system increments or decrements to the next available audio channel within the current category.

If you have just entered a new category and you rotate the [SEL] knob ...

- clockwise: the system will start with the first channel (lowest channel number) in that category.
- counter clockwise: the system will start with the last channel (highest channel number) in that category.

The CDU will wrap around after the low or high channel number is reached.

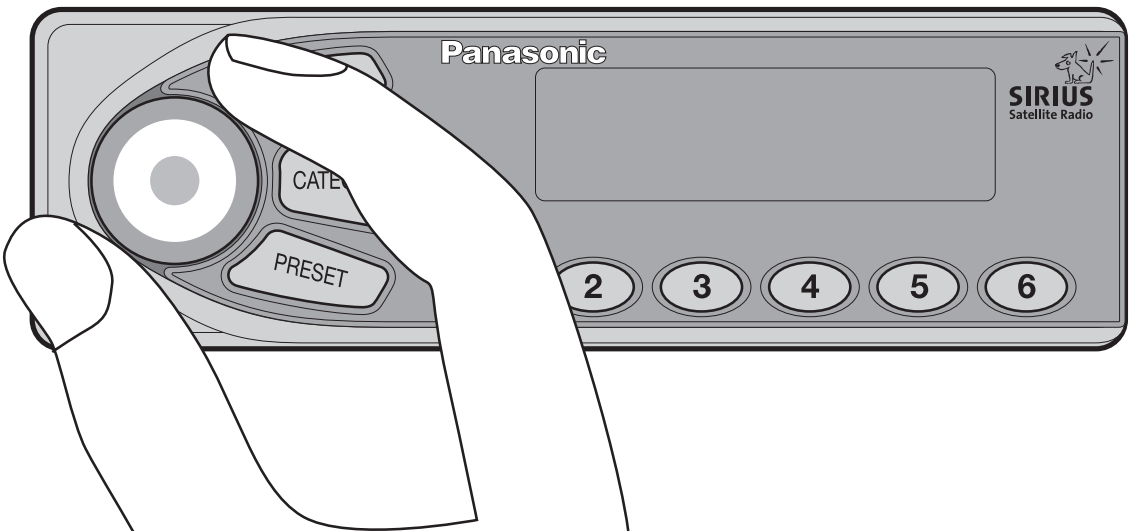

# 7.5. Channel Mode

The channel mode provides user access to all available channels in sequential order. (also called “all channels” mode)

## ENTERING CHANNEL MODE

You enter channel mode by pressing the [CHANNEL] button. The system indicates entering channel mode by illuminating the channel mode indicator located next to the channel button. No special message display occurs.

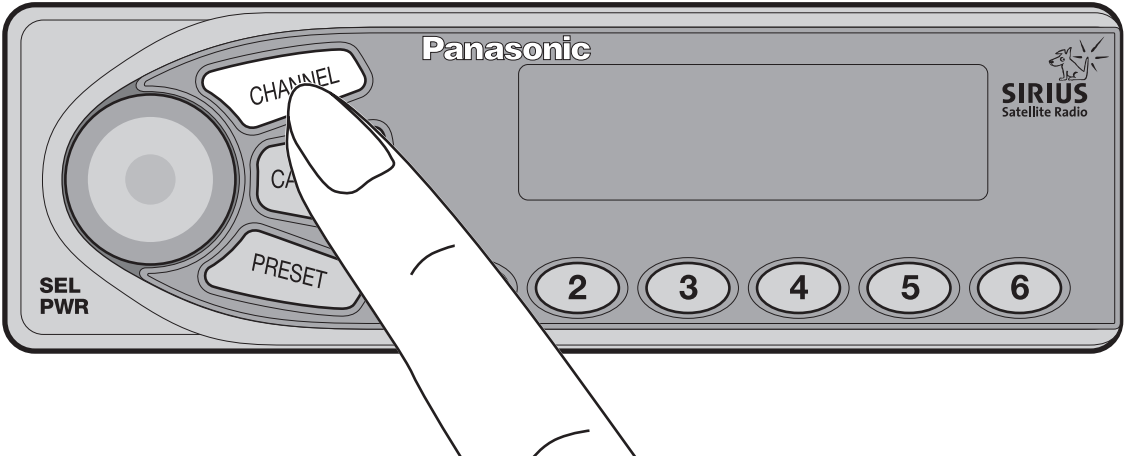

## EXITING CHANNEL MODE

You exit channel mode by entering a different mode. There are several ways to do this ...

- press the [CATEGORY] button to enter CATEGORY mode.
- press the [PRESET] button to enter PRESET mode.
- enter SETUP mode.

The system indicates exiting channel mode by turning off the channel mode indicator located next to the channel button.

## SELECTING CHANNELS WHILE IN CHANNEL MODE

As the [SEL] knob is rotated, the system will increment or decrement to the next available channel number. This channel scrolling is independent of categories or presets. For example, if you are on channel 45 (normally in the ROCK category) and you increment to the next available channel (say 49), this new channel might be in the JAZZ category. The CDU will wrap around after the low or high channel number is reached.

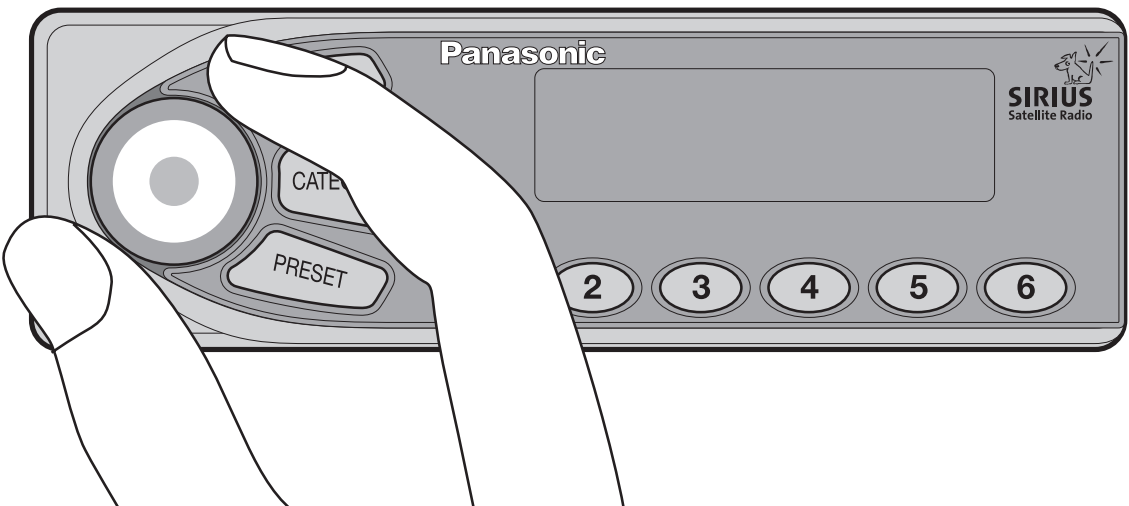

# 7.6. Preset Mode

The Sirius satellite system has a preset mode that allows the user to change channels within custom stored presets. The system has the ability to store up to eighteen presets (18 channel numbers assigned to buttons), six individual presets in three groups.

## ENTERING PRESET MODE

A user enters preset mode by pressing the [PRESET] button.

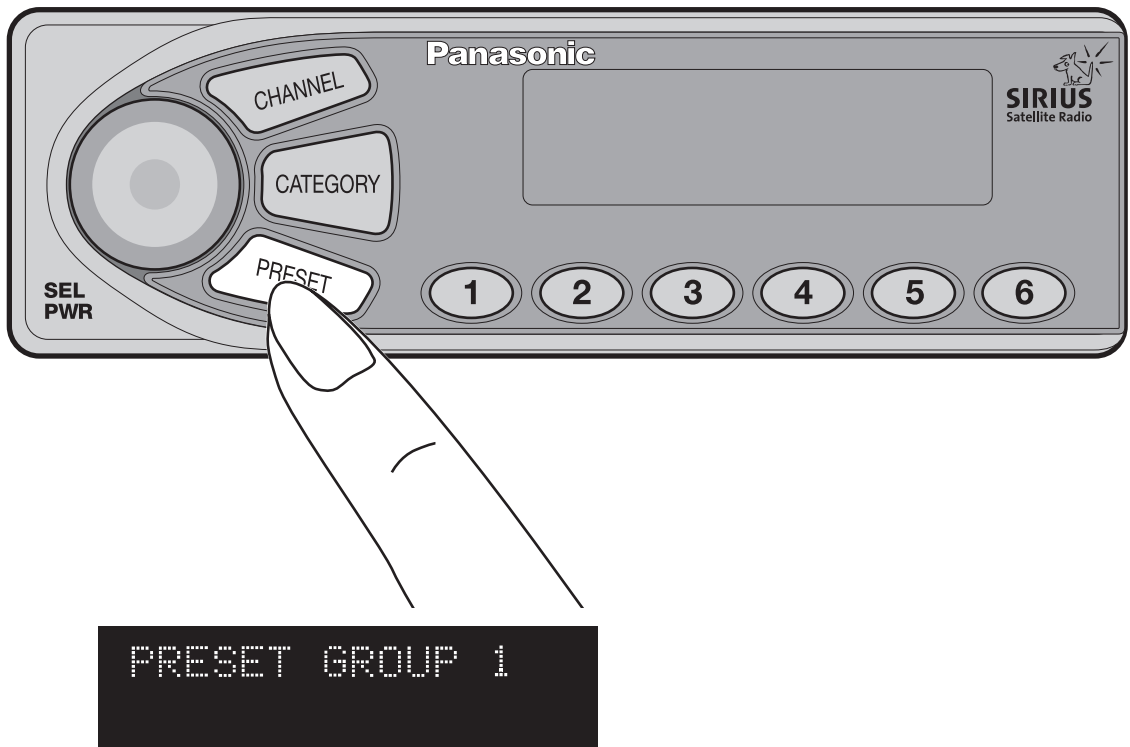

When you enter preset mode, the system indicates entering preset mode by illuminating the preset mode indicator located next to the preset button. The CDU also momentarily displays the preset mode screen (indicating the current preset group number).

Entering preset mode does not change the audio content (channel) being played. The system continues to play the same channel until [SEL] is rotated (changing the channel selection) or until a preset button [1] – [6] is pressed.



---

## EXITING FROM PRESET MODE

You exit preset mode by entering a different mode. There are several ways to do this ...

- press the [CHANNEL] button to enter CHANNEL mode.
- press the [CATEGORY] button to enter CATEGORY mode.
- enter SETUP mode.

The system indicates exiting preset mode by turning off the preset mode indicator located next to the preset button.

## SELECTING GROUPS OF PRESETS

If the preset mode screen is being displayed, further presses of the [PRESET] button cycles through the 3 groups, in ascending order, wrapping around when the last group was displayed.

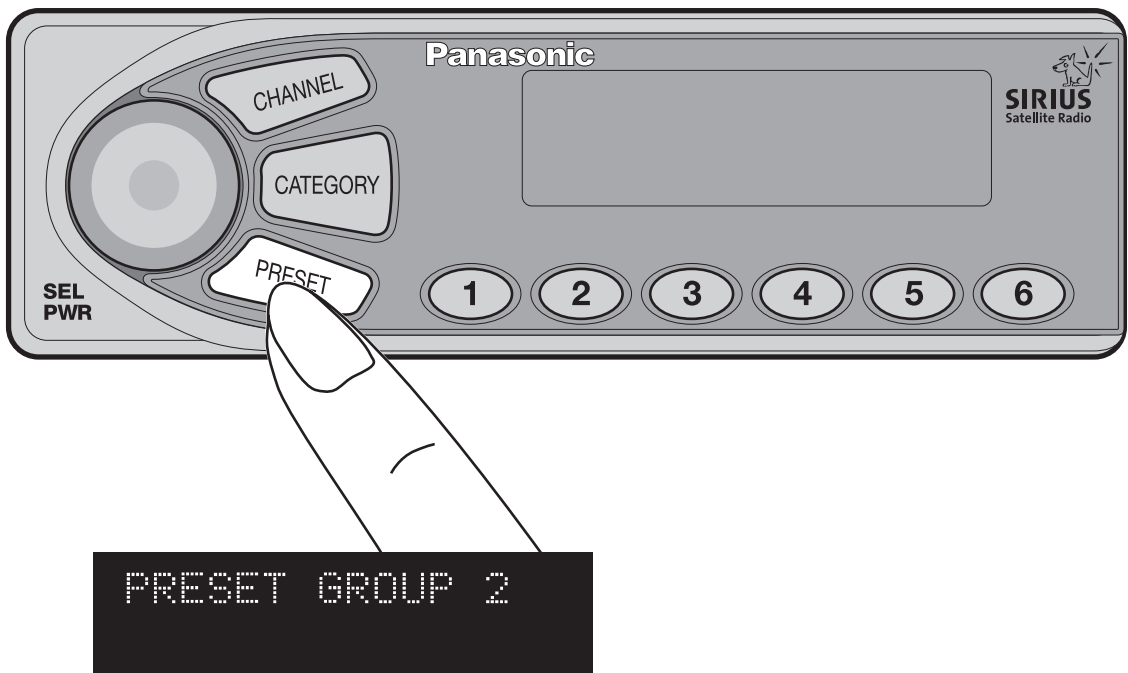

The preset mode screen will be displayed for a fixed time after the last button press of [PRESET]. Afterwards, the system returns to the previous display format and the last preset group selected becomes the “current” preset group.

---

## CHANNEL SELECTION WITHIN PRESET MODE

As the [SEL] knob is rotated, the system increments or decrements to the next preset. It will scroll through all 18 preset channels (group 1 – preset 1) through (group 3 – preset 6) starting from the current preset group.

After reaching the end of the presets, further turning of the [SEL] knob will wrap around the preset groups such that if [SEL] is rotated:

- clockwise past (group 3 – preset 6) ... (group 1 – preset 1) will be selected.
- counter-clockwise past (group 1 – preset 1) ... (group 3 – preset 3) will be selected.

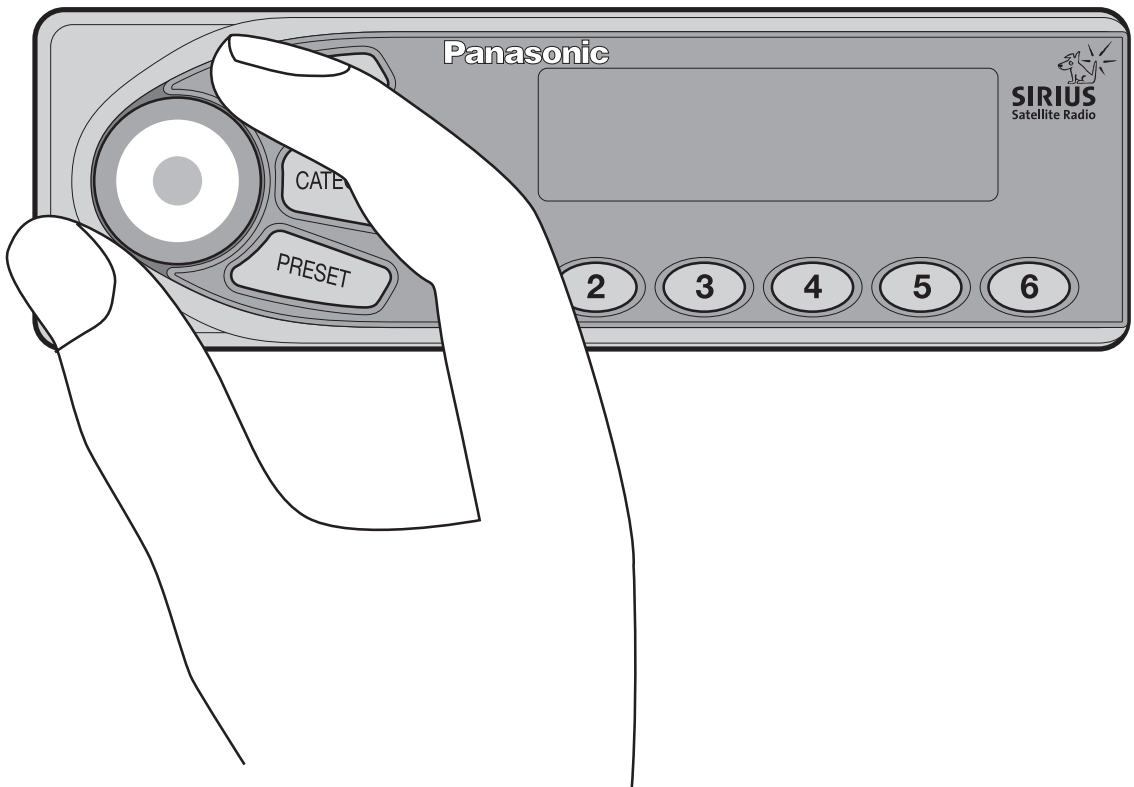

# 8. System Components & Specifications

---

There are 5 basic components to the system:

1. SSR Receiver
2. Antenna (Sold Separately)
3. Controller / Display Unit (Included in CR-SRF100)
4. FM Modulator (Included in CR-SRF100)
5. Receiver Wiring Harness
6. Installation Instructions Guide Supplied Hardware
7. Mounting Screws for Receiver (4)
8. Dual-lock Fasteners for Control Display unit (2 sets)

# 8.1. SSR Receiver ... (CR-ZX0161Z)



## SPECIFICATIONS:

- Operating Temperature Range:  $-40^{\circ}\text{C}$  to  $+85^{\circ}\text{C}$
- Power Supply: 12VDC (9 – 16VDC), Negative Ground
- Max RMS Current Consumption: less than 2.0A @  $25^{\circ}\text{C}$  14v
- Peak Current Consumption: less than 2.5A @  $25^{\circ}\text{C}$  14v
- Dimensions: 195mm(L) x 141mm(W) x 32mm(H)
- Weight: 1.1 kg
  
- Frequency Range ... S-Band: 2319.75MHz to 2332.75MHz
- Audio Output Level: 2 Vrms differential (1 Vrms single ended)
- Signal to Noise Ratio: -95db (A-Weighted)
- Stereo Separation: 56dB @ 1KHz
  
- Connector 1 (Satellite Antenna Input) type: Blue FAKRA connector.
- Connector 2 (Terrestrial Antenna Input) type: White FAKRA connector.
- Connector 3 (I/O Connector) type: 20 circuit automotive connector

## 8.2. Control Display Unit (CDU) ... (CY-CX0160Z)

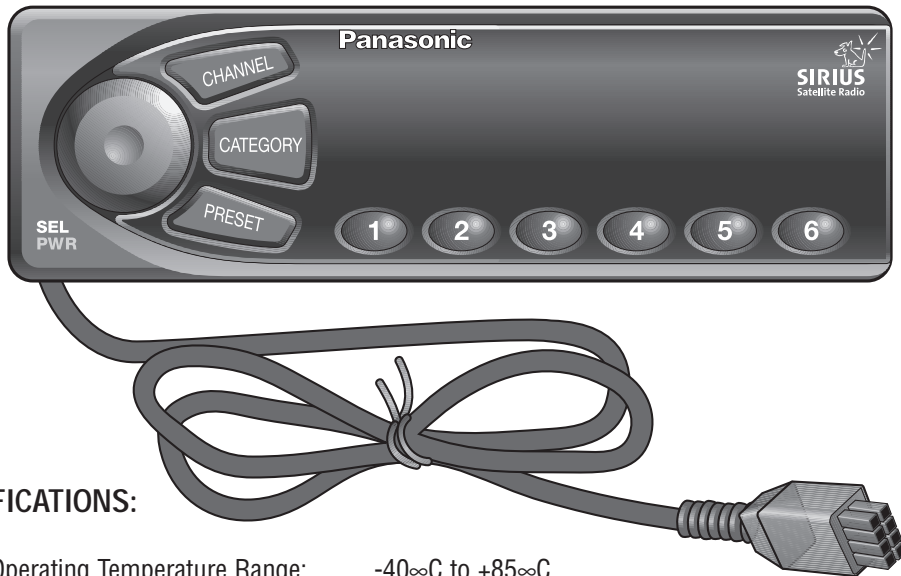

### SPECIFICATIONS:

- Operating Temperature Range:  $-40^{\circ}\text{C}$  to  $+85^{\circ}\text{C}$
- Power Supply:  $+5.8\text{ VDC}$
- Nominal Current Consumption:  $360\text{ mA}$
- Dimensions:  $149\text{mm(L)} \times 47\text{mm(W)} \times 33\text{mm(H)}$
- Weight:  $0.25\text{ kg}$
  
- Display output: 2 line x 16 character VFD display output.
- Indicator output: 3 separate LEDs
  
- Lead type & length: 2 meters long – 6-wire (24 AWG) – with shielding.
- Connector type: 8 position plug

## 8.3. FM Modulator ... (CY-ZX0160Z)

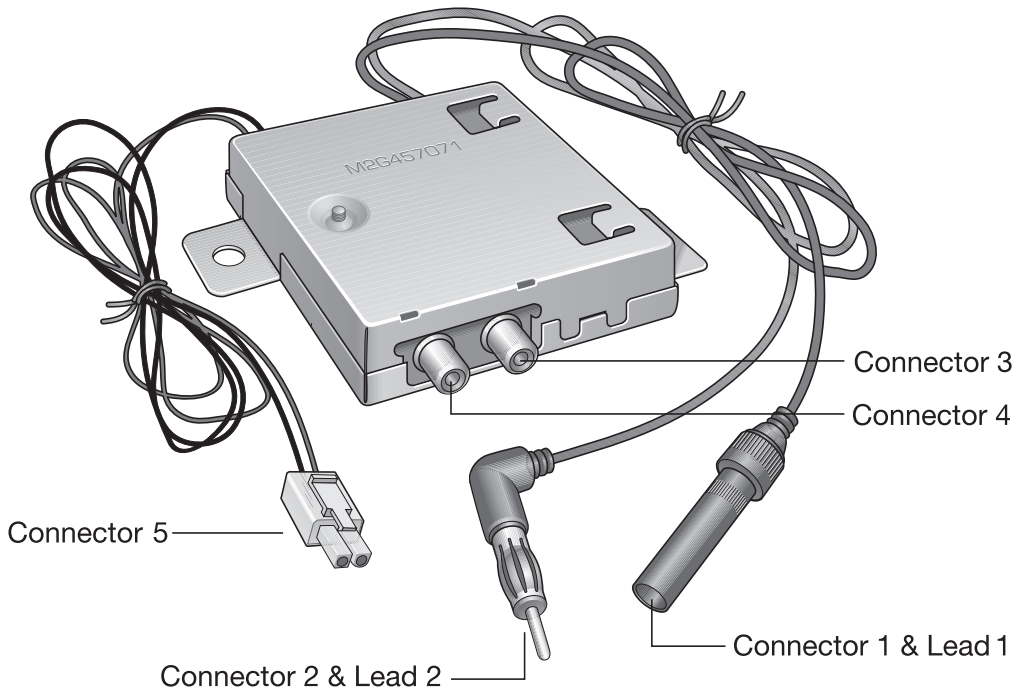

### SPECIFICATIONS:

- Operating Temperature Range:  $-40^{\circ}\text{C}$  to  $+85^{\circ}\text{C}$
- Power Supply: 12VDC (9 – 16), Negative Ground
- Max RMS Current Consumption: 90 mA
- Dimensions: 87mm(L) x 106mm(W) (“ear-to-ear”) x 22mm(H)
- Weight: 0.25 kg
- Frequency Range: 10 frequencies  
(88.7 MHz --> 90.5 MHz in 0.2 MHz increments)
- RF Output Power: -25dB
- Max Input Audio: 2 Vrms
- Signal to Noise Ratio: > 45dB
- Stereo Separation: > 50dB
- Lead 1 (Antenna Input) type & length: Red 22 AWG center conductor shielded wire with:
  - black insulation (1 meter long)
  - connector 1 (Antenna Input) type with standard antenna connector (receptacle).
- Lead 2 (RF Output) type & length: White 22 AWG center conductor shielded wire with:
  - black insulation (1 meter long)
  - connector 2 (RF Output) type with standard antenna connector (jack).
- Connector 3 (left audio input) type: White RCA male connector
- Connector 4 (right audio input) type: Red RCA male connector
- Connector 5 (FM Modulator control): 2-wire connector (3.5 meter wire length):
  - Lead 5: 22 AWG black ground wire
  - Lead 6: 22 AWG cyan & yellow control wire

# 8.4. Receiver Wiring Harness... (M2C457018)

(Included with CR-SRF100 Kit)

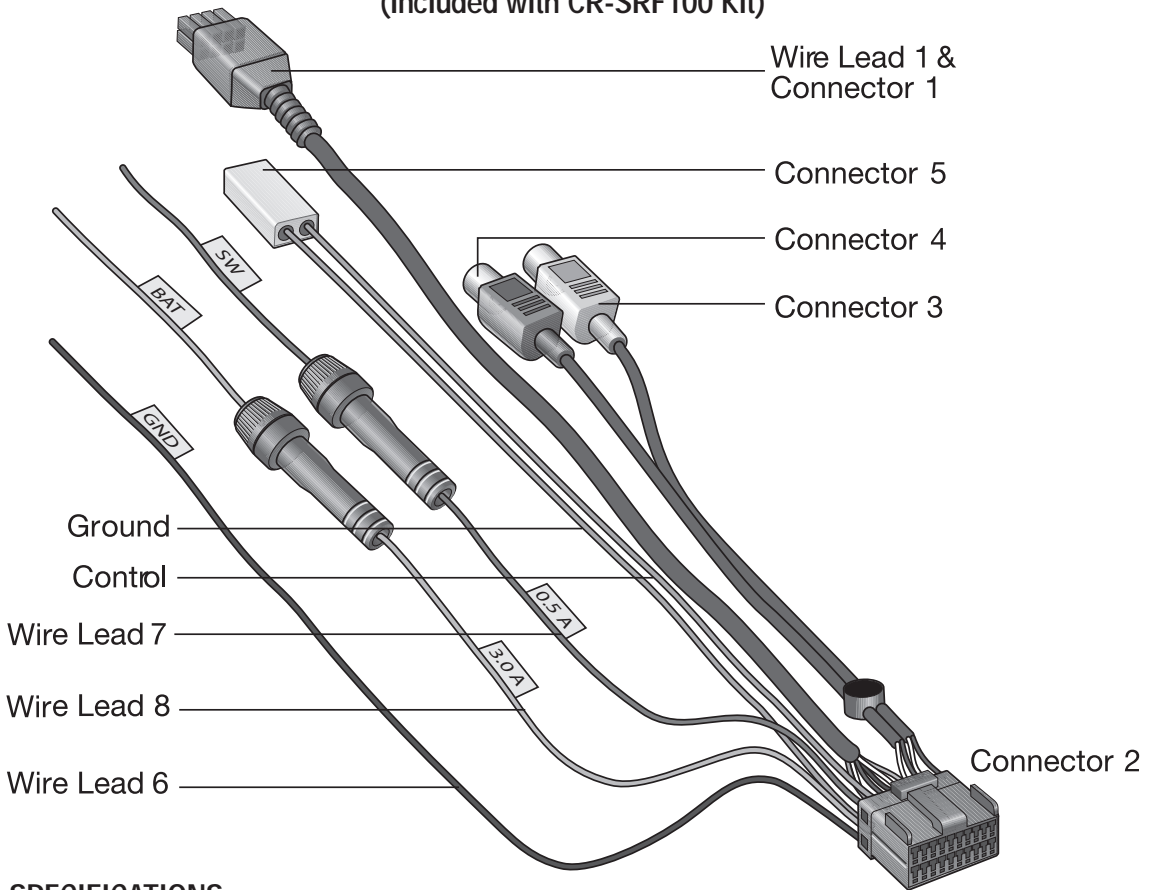

## SPECIFICATIONS:

- Connector 1 (CDU connector): 8 position plug
- Wire type & length: 4 meters – 6-wire (22 AWG) – with shielding.
- Connector 2 (I/O Connector): 20 circuit automotive connector
- Connector 3 (left audio input): white RCA female connector (0.4 meter wire length)
- Connector 4 (right audio input): red RCA female connector (0.4 meter wire length)
- Connector 5 (FM Modulator control): 2-wire connector (0.65 meter wire length):  
20 AWG cyan & yellow control wire  
20 AWG black ground wire
- Lead 6 (Ground): 20 AWG black wire (0.65 meter wire length)
- Lead 7 (Accessory power): 20 AWG red wire (0.65 meter wire length)  
with 0.5A in-line fuse)
- Lead 8 (+ Battery power): 20 AWG yellow wire (0.65 meter wire length)  
with 3A in-line fuse)

# 8.5. Receiver Wiring Harness...(M2C457019)

(Included with CR-SRT100 Kit)

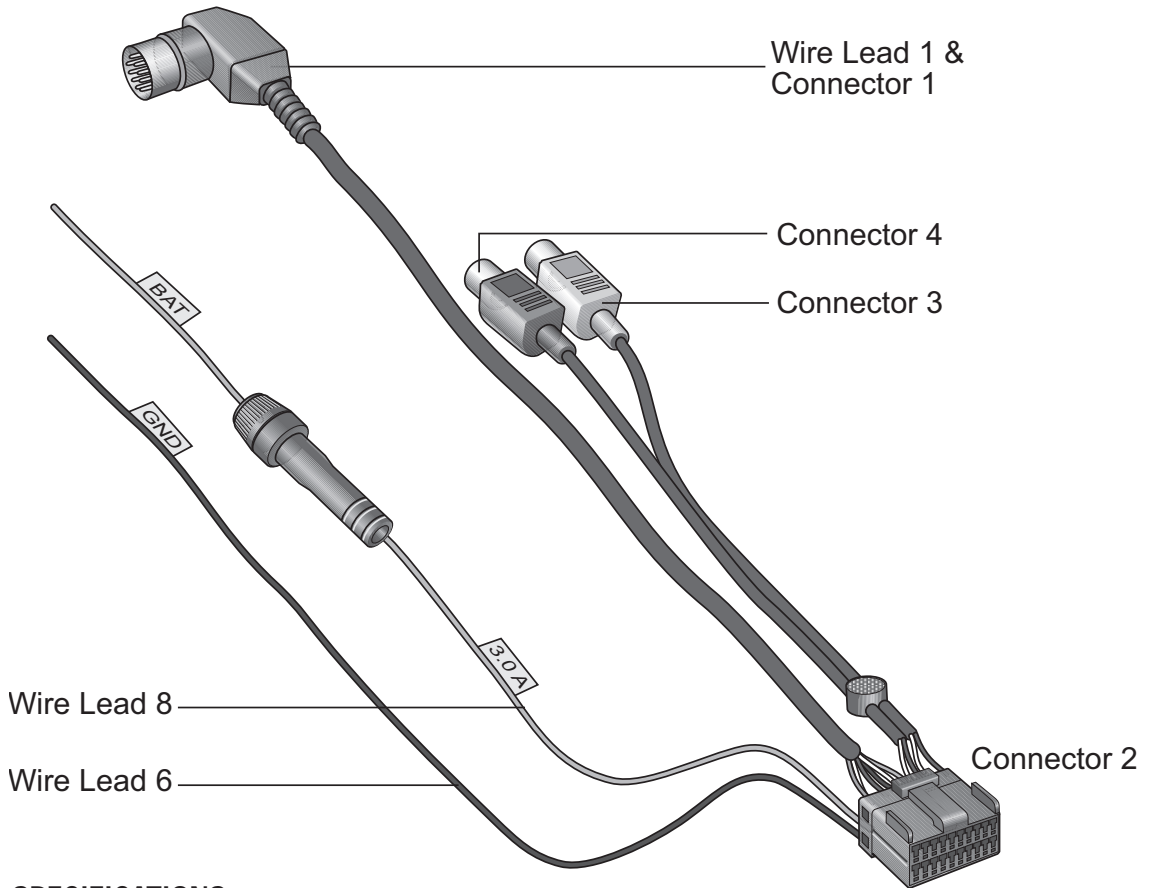

## SPECIFICATIONS:

- Connector 1 (CDU connector): 8 position plug
- Wire type & length: 6 meters – 6-wire (22 AWG) – with shielding.
- Connector 2 (I/O Connector): 20 circuit automotive connector
- Connector 3 (left audio input): white RCA female connector (0.4 meter wire length)
- Connector 4 (right audio input): red RCA female connector (0.4 meter wire length)
- Lead 6 (Ground): 20 AWG black wire (0.65 meter wire length)
- Lead 8 (+ Battery power): 20 AWG yellow wire (0.65 meter wire length) with 3A in-line fuse



# 9. Diagrams & Installation

---

## 9.1. General System Diagrams

---

WITHOUT FM MODULATOR

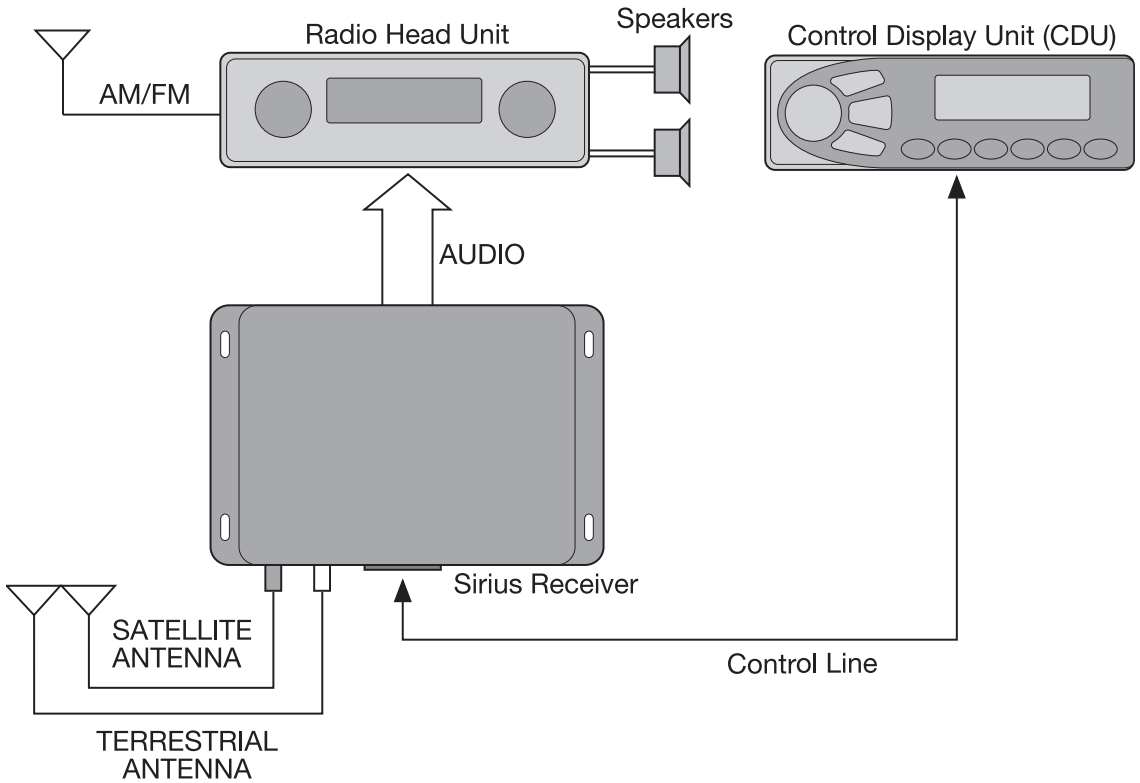

## WITH FM MODULATOR

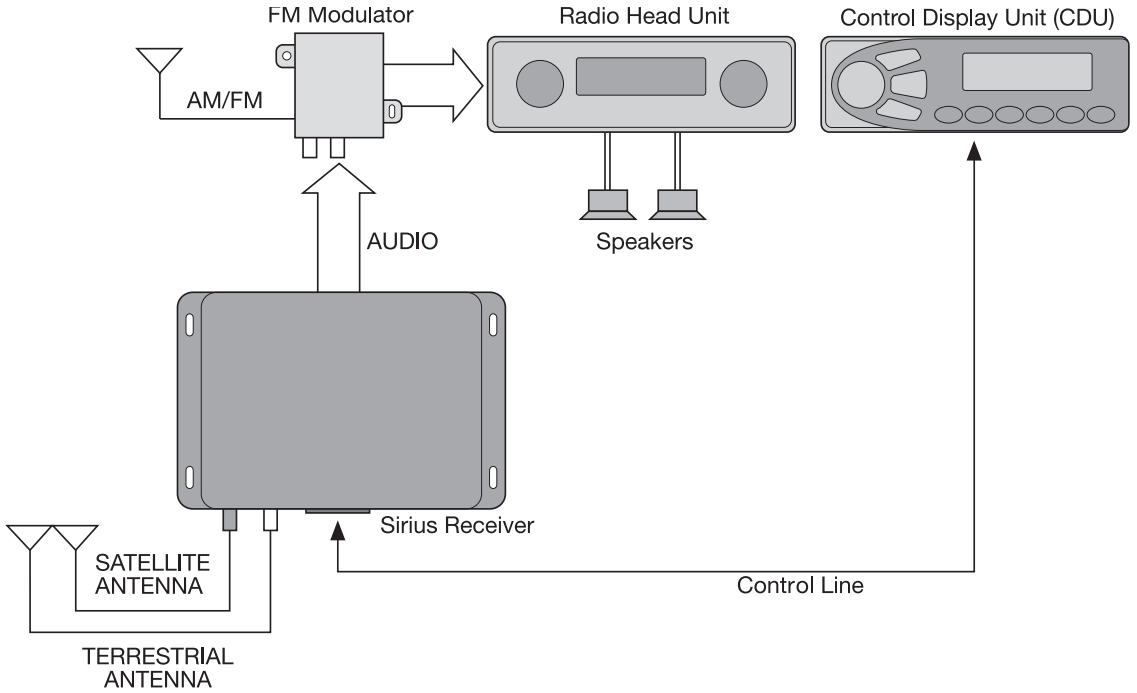

## WITHOUT CDU ... WITH SIRIUS ENABLED RADIO HEAD UNIT

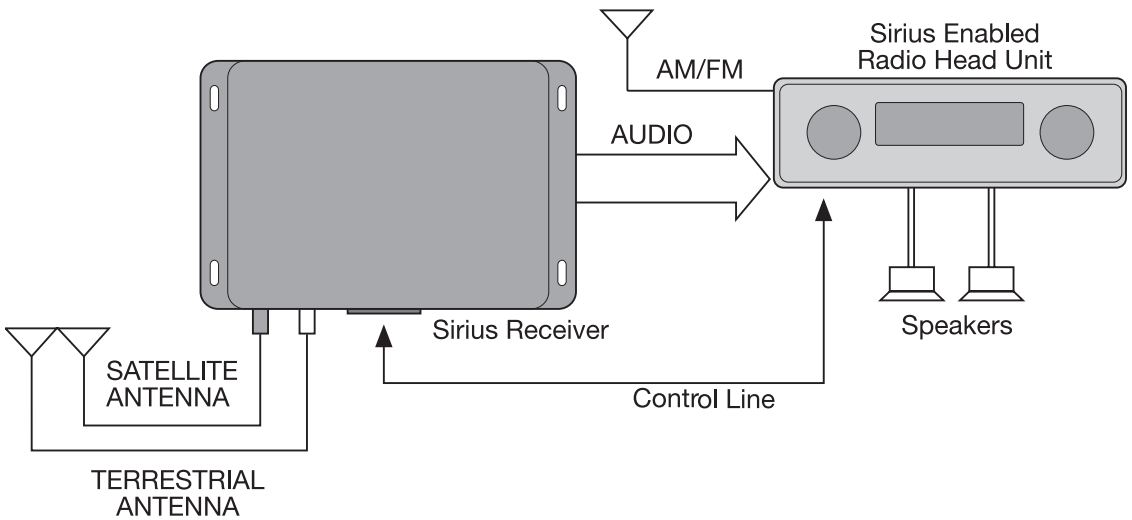

# 9.2. General Connection Diagram

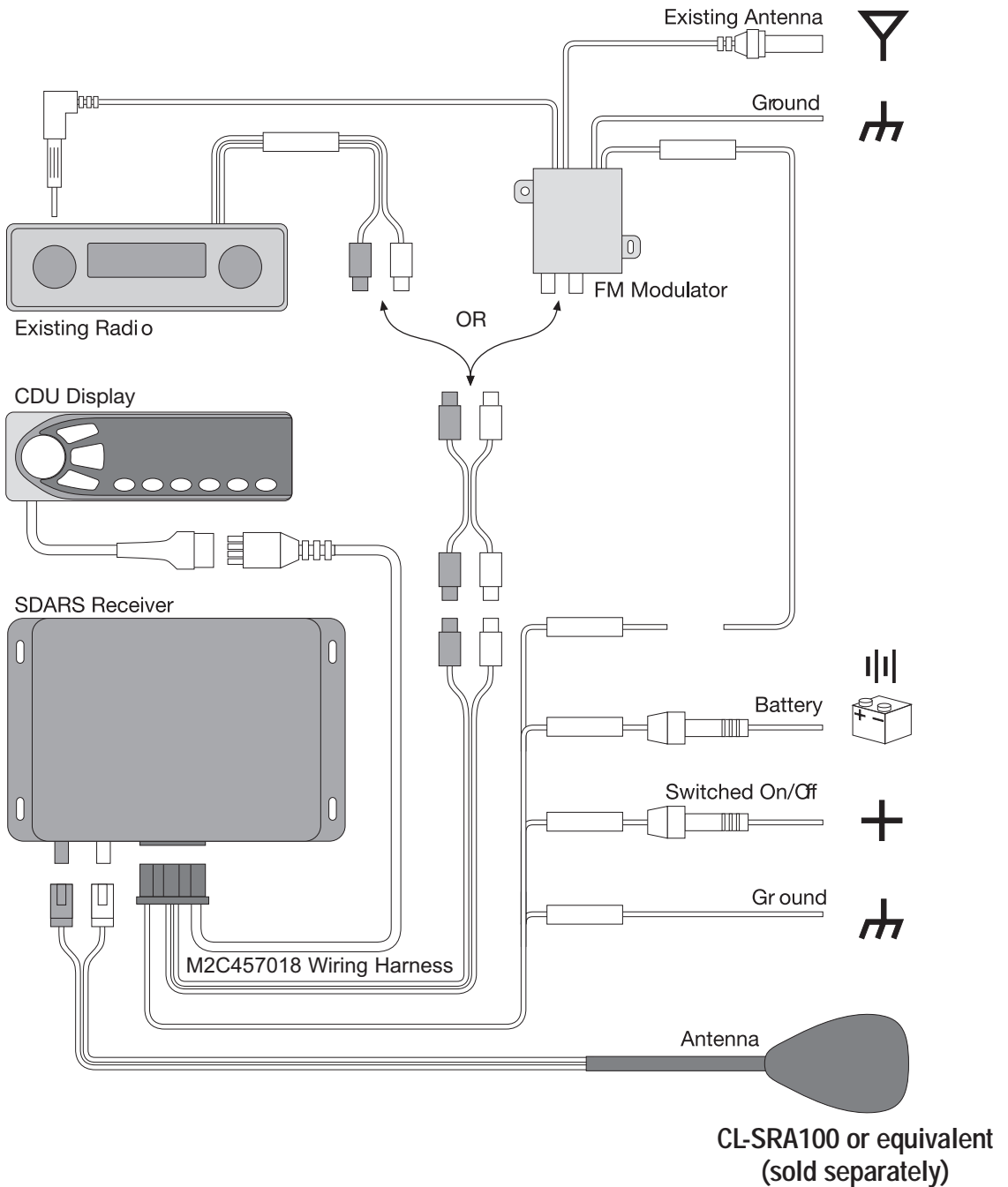

**CR-SRF100**

## 9.2. General Connection Diagram Continued

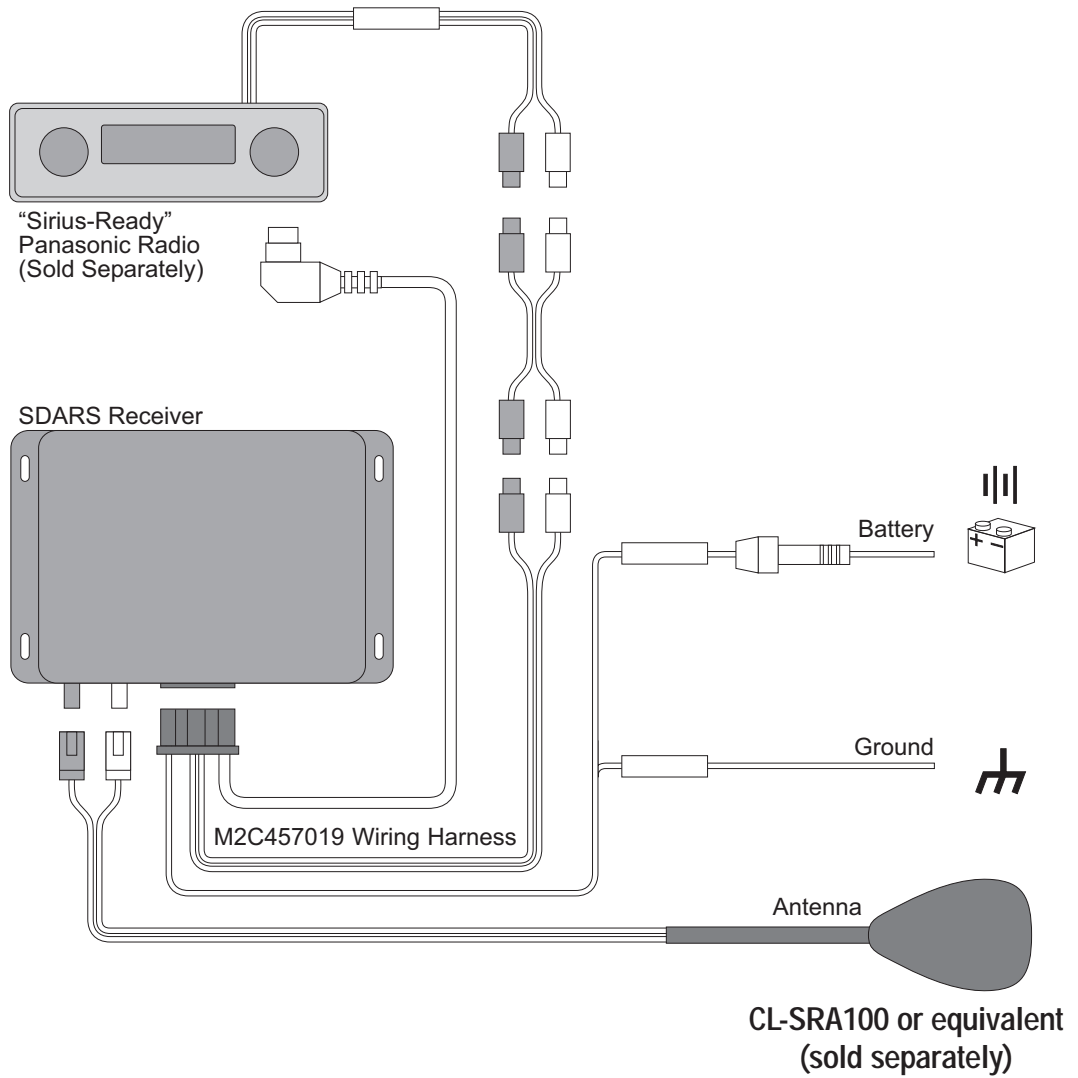

**CR-SRT100**

# 9.3. Installation

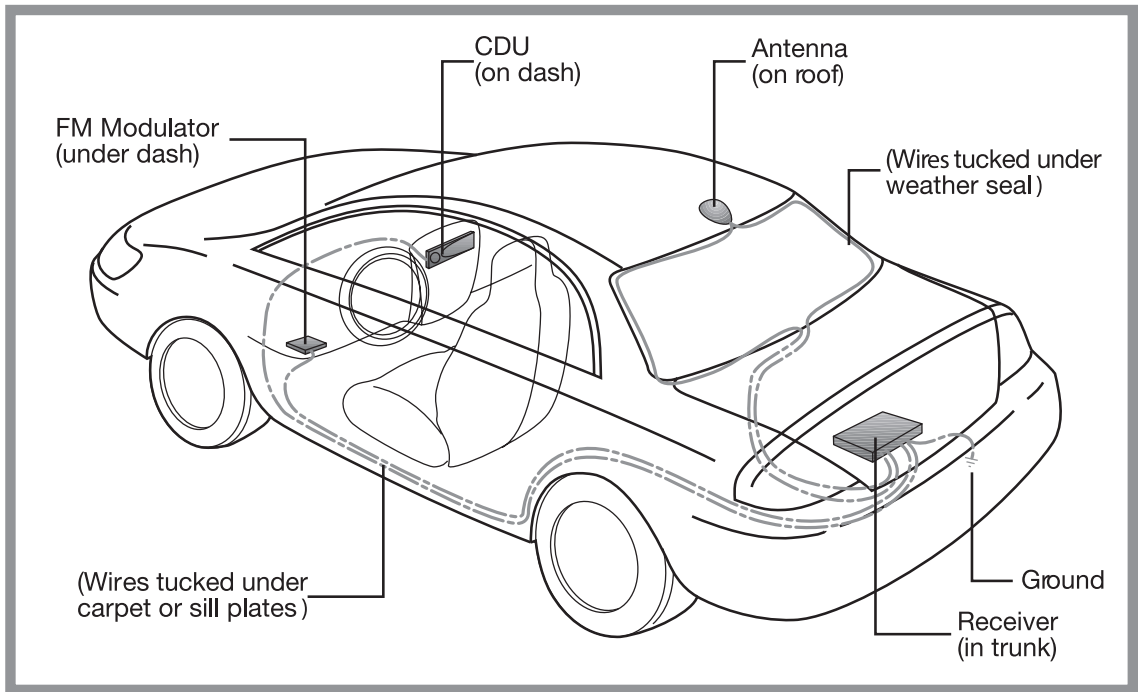

## POINTS:

- The receiver must be installed inside the vehicle...not in direct contact with the elements (e.g., rain, snow). It should be securely fastened to the vehicle.

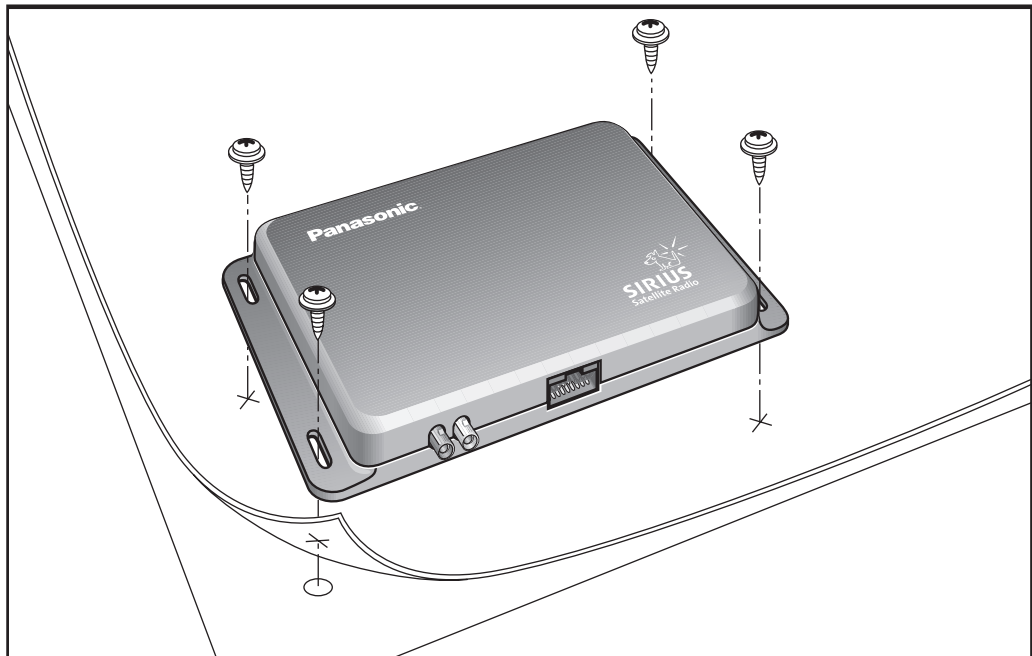

The antenna is sold separately. Read and follow instructions included with the antenna. Information below is provided as reference only.

- The antenna should be installed on the vehicle's roof with the 2 wires separating and going around the rear window before entering the vehicle and going to the receiver. The antenna is fastened to the roof top with self-adhesive tape located on the bottom of the antenna housing.

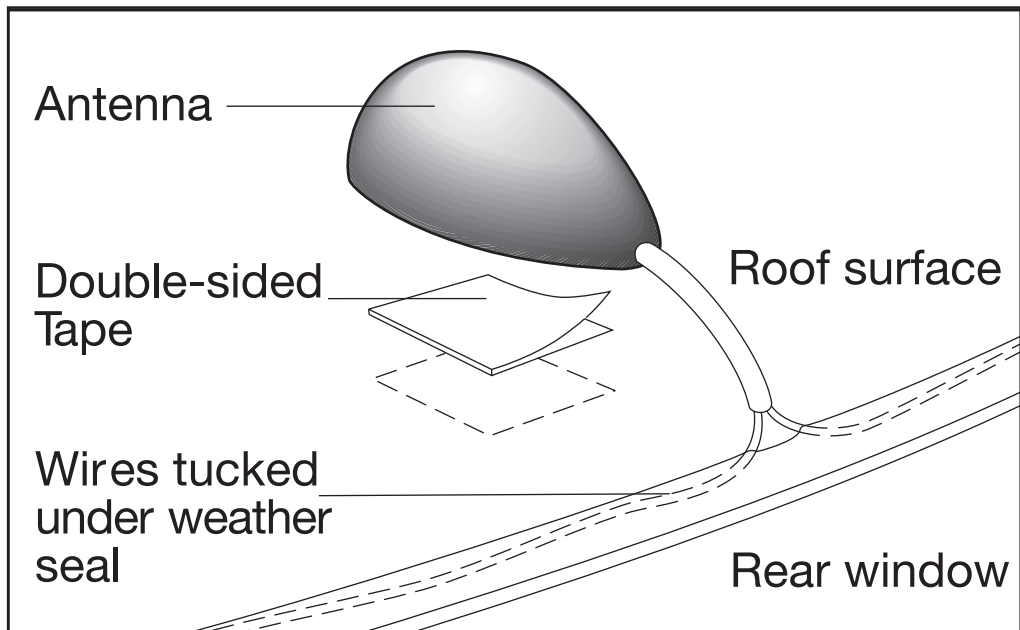

To obtain optimum adhesion, the bonding surface must be clean, dry and well unified. Typical surface cleaning solvents are isopropyl alcohol/water mixture (rubbing alcohol) or heptane. However, if placing it on a painted surface, test first to ensure no damage to the surface will occur.

- Use a clean cloth to clean surface.
- Use proper safety precautions for handling solvents.

It may be necessary to seal or prime some substrates prior to bonding:

- a. Most porous or fibered materials (e.g. wood) will require sealing to provide a unified surface.
- b. Some materials (e.g. copper, brass, plasticised vinyl) will require priming or coating to prevent interaction between adhesive and substrates.

Ideal tape application temperature is 20°C to 38°C (68°F to 100°F). Do not apply to surfaces below 10 degrees Celsius.

In some cases, bond strength can be increased and ultimate bond strength can be achieved more quickly by exposure of the bond to elevated temperatures (e.g. 85°C [185°F] for one hour).

**Warning:** Panasonic is not responsible for scratches or other surface damage that might result from removing a Satellite Radio Antenna after it has been installed.

- The FM modulator should be mounted under the dash board...as close as possible to the existing radio / head unit.

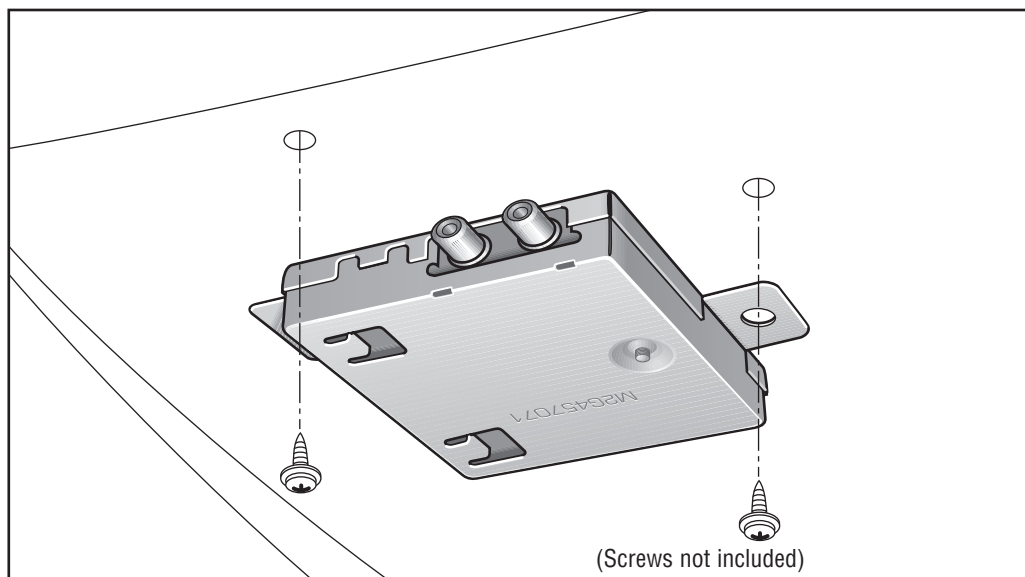

- The Control Display Unit (CDU) should be installed at a convenient location on the dash board. It should be installed where it will not cause driver distraction. It is mounted with “dual-lock fastening tape” (included in the kit). However, it should not be mounted where it will be exposed to direct and extended sun light (i.e., do not mount it on top of the dash board under the windshield in direct sun light).

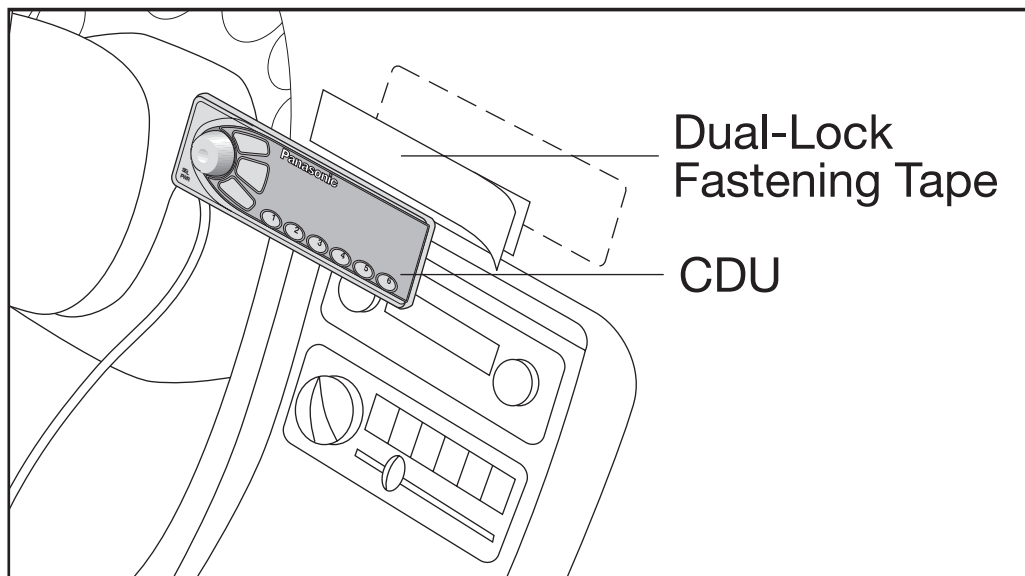

# 10. Maintenance & Troubleshooting

---

## 10.1 Maintenance

---

Your product is designed and manufactured to ensure the minimum of maintenance. Use a soft cloth for routine exterior cleaning. Never use benzine or other solvents.

## 10.2 Troubleshooting

---

Direct access channel 184 is provided by Sirius Satellite Radio to confirm proper installation of all the system components.

If the receiver acquires channel 184, the system is installed / working properly. If all components are working as described in this manual, however you are experiencing difficulty with programming reception, contact the Sirius Technical assistance phone number 1-888-539-SIRIUS (7474).

If the receiver does not acquire channel 184 properly, please reconfirm proper installation and setup per the instructions included in this manual.

After verifying proper installation and setup you are still experiencing trouble, check the following items:

### 1. KEYPAD ERROR

When the SSR system starts, if the CDU never detects that all of the keys are released at the same time, a "KEYPAD ERROR" message is displayed (the CDU has determined that a key is stuck in the pressed state).



KEYPAD ERROR

Action: Check CDU for a key which is stuck down.

### 2. INITIALIZING

If the CDU cannot communicate with the receiver at startup, INITIALIZING is displayed. This may be temporarily displayed if the user presses a key during the "SIRIUS SATELLITE RADIO" scrolling, and is not necessarily a problem.



INITIALIZING

Action: If the message does not go away after approx. 6 seconds, check the electrical harness to the receiver.



---

### 3. RECEIVER ERROR

If communication between the receiver and CDU stops for approximately 6-9 seconds, then a “RECEIVER ERROR” message is displayed).



RECEIVER ERROR

Action: Check the electrical harness between the CDU and the receiver.

### 4. NO SUBSCRIPTION

If the CDU determines that there is no subscription to the Sirius service, then the message “CALL 888-539-SIRIUS TO SUBSCRIBE” will scroll twice on the display. Pressing any key will then cause the Sirius ID to be displayed. Further key presses alternate between the Call Sirius message and the Sirius ID.



SIRIUS TO SUBSCR

Action: Subscribe according to the instructions earlier in this manual.

### 5. ANTENNA ERROR

If the receiver detects an electrical problem with the antenna circuit, the “ANTENNA ERROR” message will be displayed on the second line.



ANTENNA ERROR

Action: Verify the electrical connection between the receiver and both antenna wires.

### 6. ACQUIRING SIGNAL

If there is a lack of both a satellite and terrestrial signal, the “ACQUIRING SIGNAL” message will be displayed on the second line.



ACQUIRING SIGNAL

Action: Make sure the antenna is not obstructed by any large objects (bridges, garages, tall buildings, etc.)

---

## 7. POWER UP AND HEARING STATIC ON SYSTEM WITH FM MODULATOR

If you power the SSR system up and are using an FM modulator and you only hear static, your radio might be on the wrong FM station. The radio must be on the same FM station that the SSR system is set to.

Action: Check that your radio is tuned to the correct FM frequency.  
(Please see the section on the setup operation to view or change the required FM modulator frequency).

## 6. POWER UP AND HEARING AN "OVER THE AIR" STATION ... NOT AN SSR STATION

In a system that requires an FM modulator, if your FM modulator is set to "OFF" (see SETUP mode ... FM Modulator configuration), you will not hear any SSR stations and your "over the air" antenna system will be functioning normally. Therefore, in this situation, you will be receiving "over the air" stations.

Action: Check that your receiver is set to use the FM modulator on the correct FM frequency.

If you are unsuccessful in resolving troubles, please refer to Product Servicing below.

---

# 10.3 Product Servicing

If you experience any operational difficulties, or require a repair, please refer to the original installer or your supplying dealer for assistance. Otherwise, call Panasonic Customer Call Center phone number 1-800-211-PANA.

---

## 10.4 Replacing The Fuse

Use fuses of the same specified rating 3A for yellow wire and 0.5A for red wire. Using different substitutes or fuses with higher ratings, or connecting the unit directly without a fuse, could cause fire or damage to the receiver system. If the replacement fuse fails, contact the Panasonic Customer Service 1-800-211PANA (7262) for assistance.

---

## 10.5 Antenna Removal

Antennas are sold separately. Each antenna manufacturer may have instructions that are specific to their own products. You should follow the instructions from your antenna manufacturer.

**Warning:** Panasonic is not responsible for scratches or other damage that might result from removing a Satellite Radio Antenna after it has been installed.

# Notes

---

# Notes

---

Panasonic Consumer Electronics Company  
Division of Matsushita Electric Corporation of America  
One Panasonic Way  
Secaucus, NJ 07094  
<http://www.panasonic.com>

CA-MX0260ZC Printed in U.S.A.